

6 SKYLIGHT DETAIL
3/4" = 1'-0"

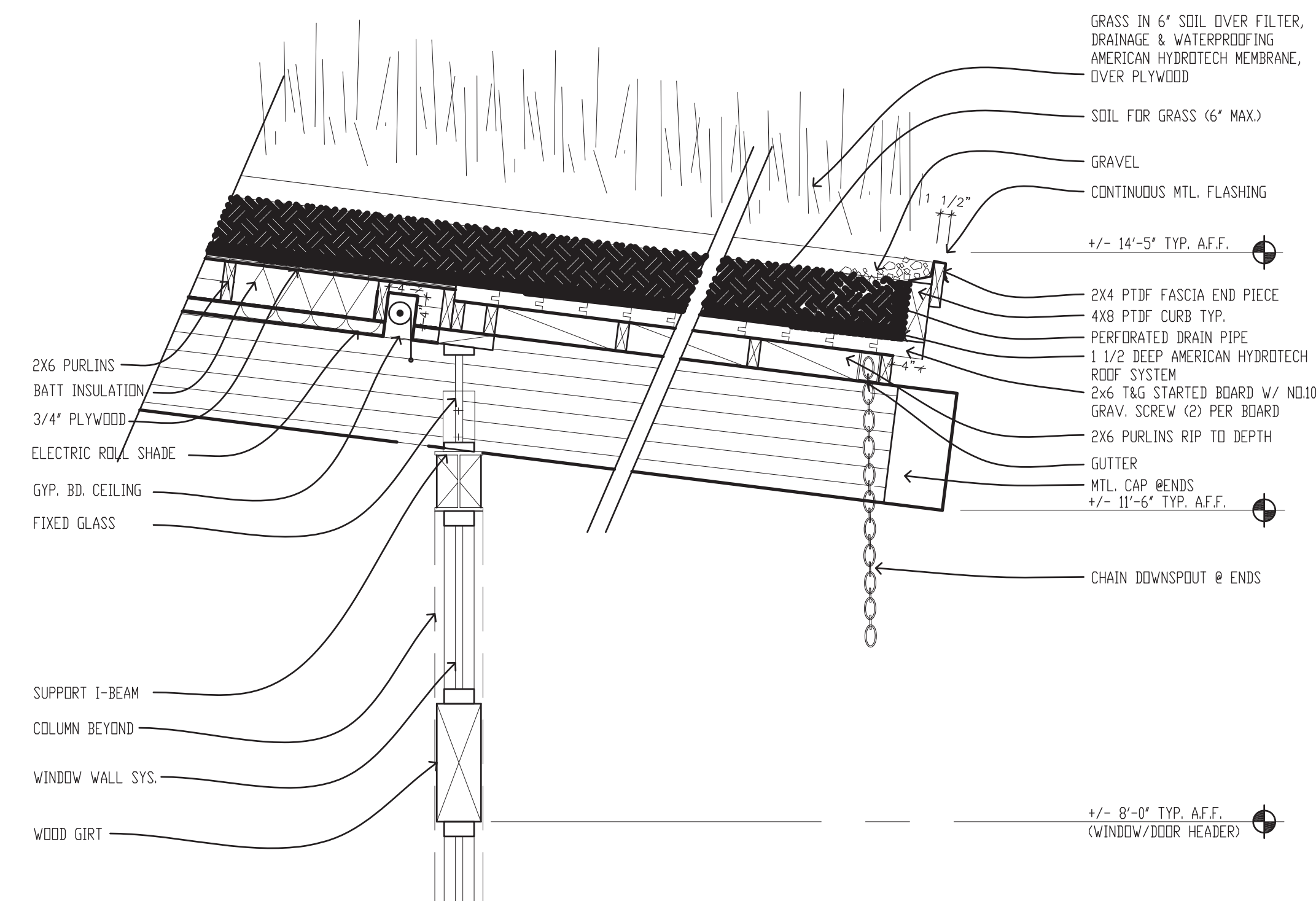

7 EAVE DETAIL
3/4" = 1'-0"

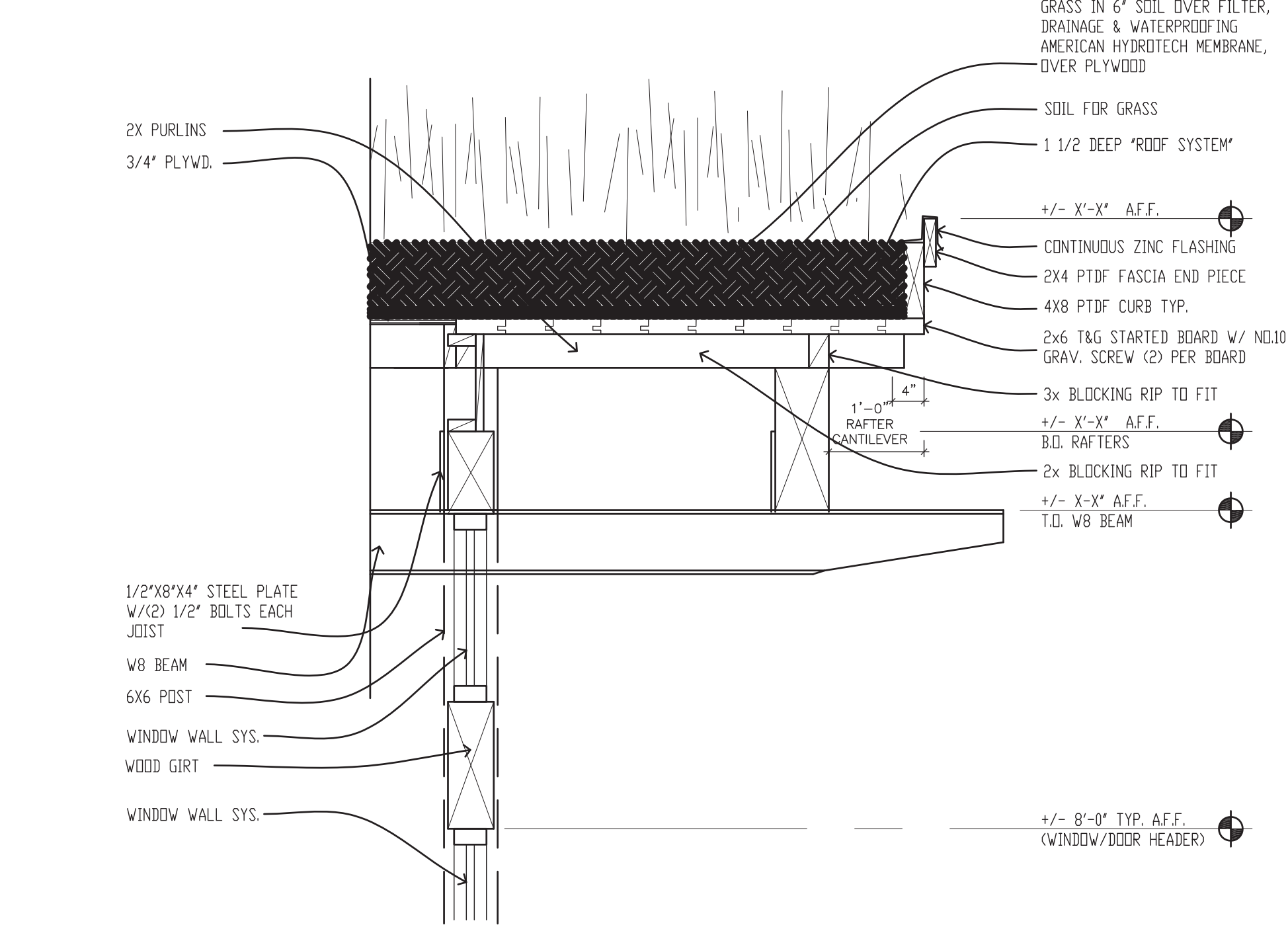

8 RAKE DETAIL
3/4" = 1'-0"

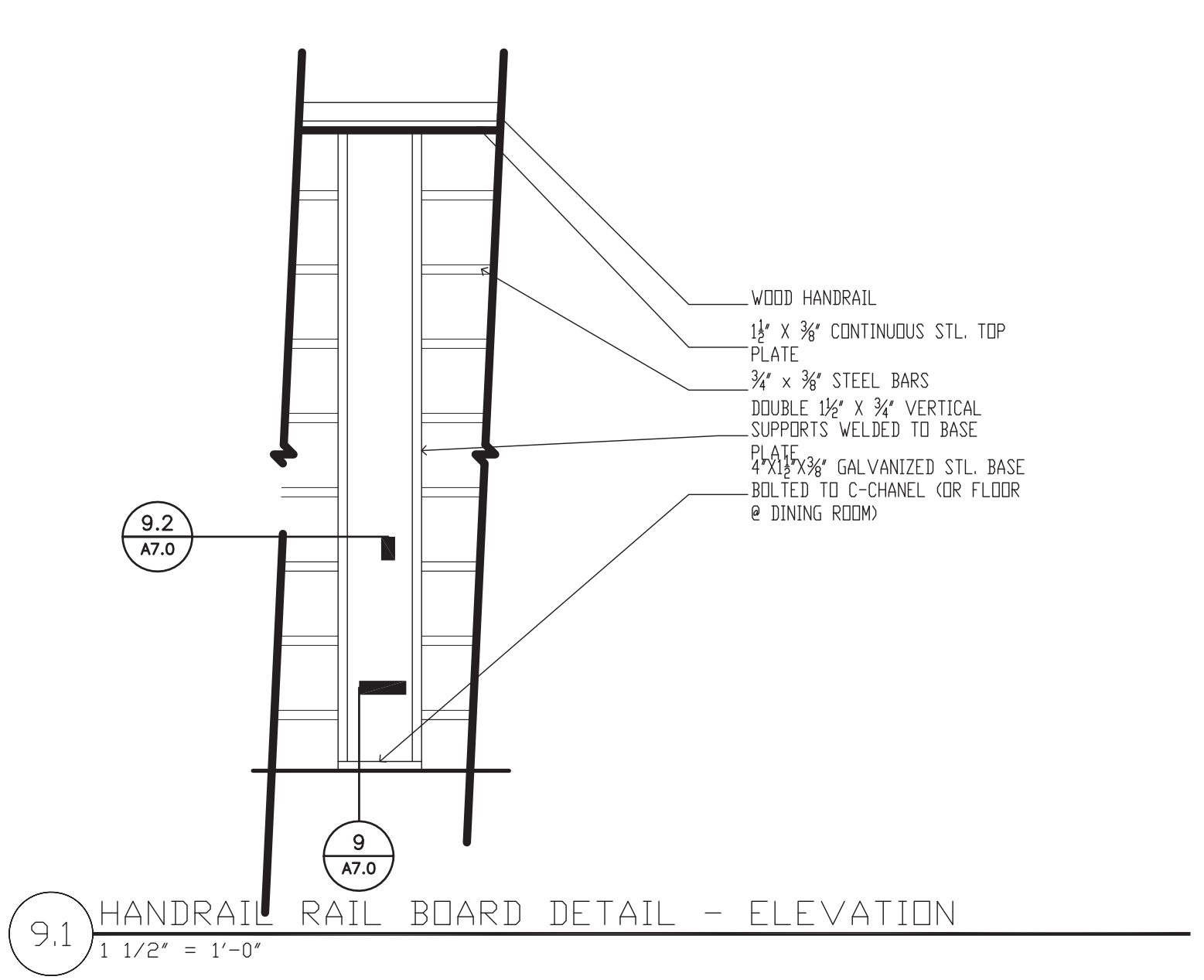

9.1 HANDRAIL RAIL BOARD DETAIL - ELEVATION
1 1/2" = 1'-0"

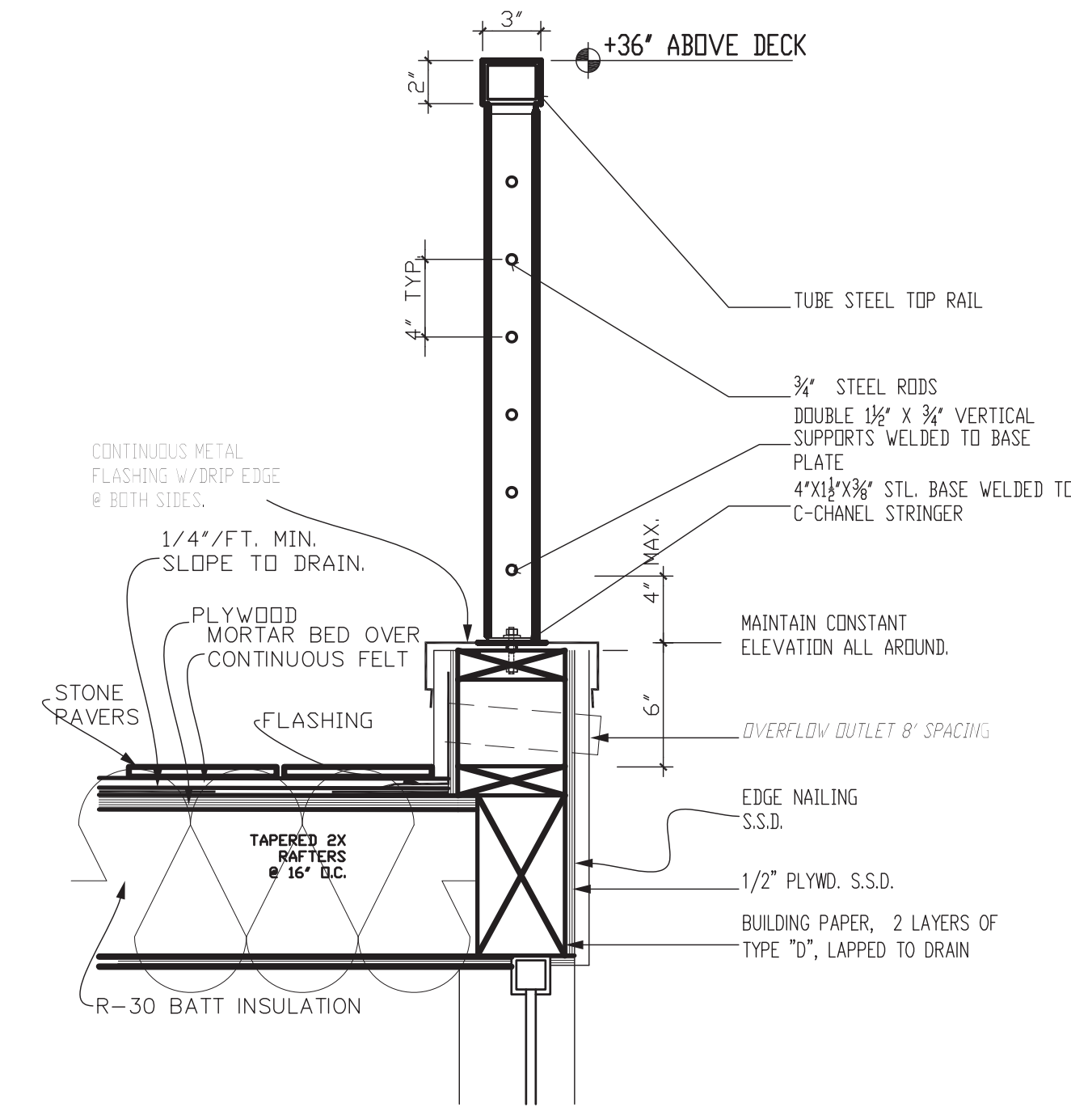

9 DECK CURB AND HANDRAIL
1 1/2" = 1'-0"

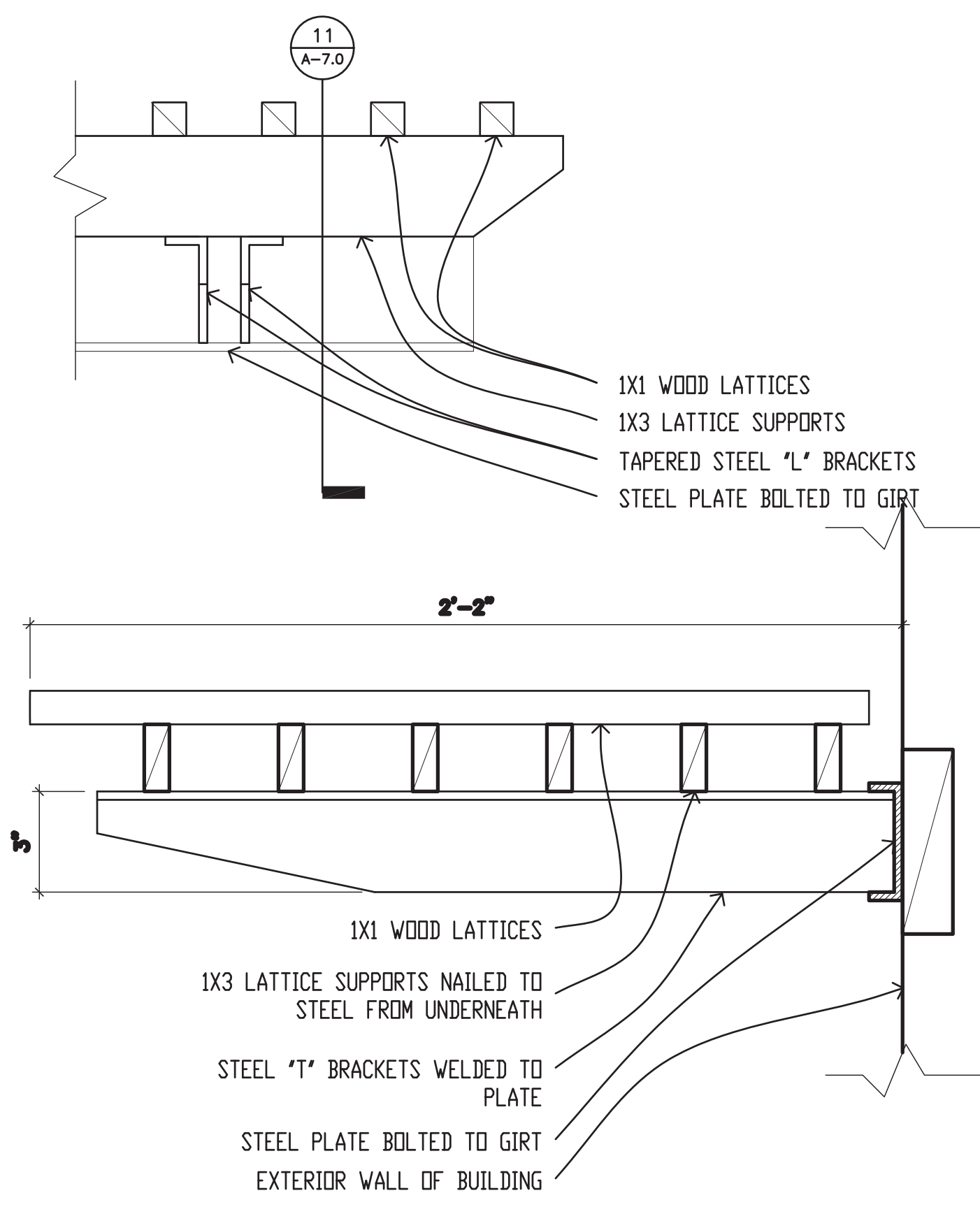

11 SUN SHADE DETAILS
3" = 1'-0"

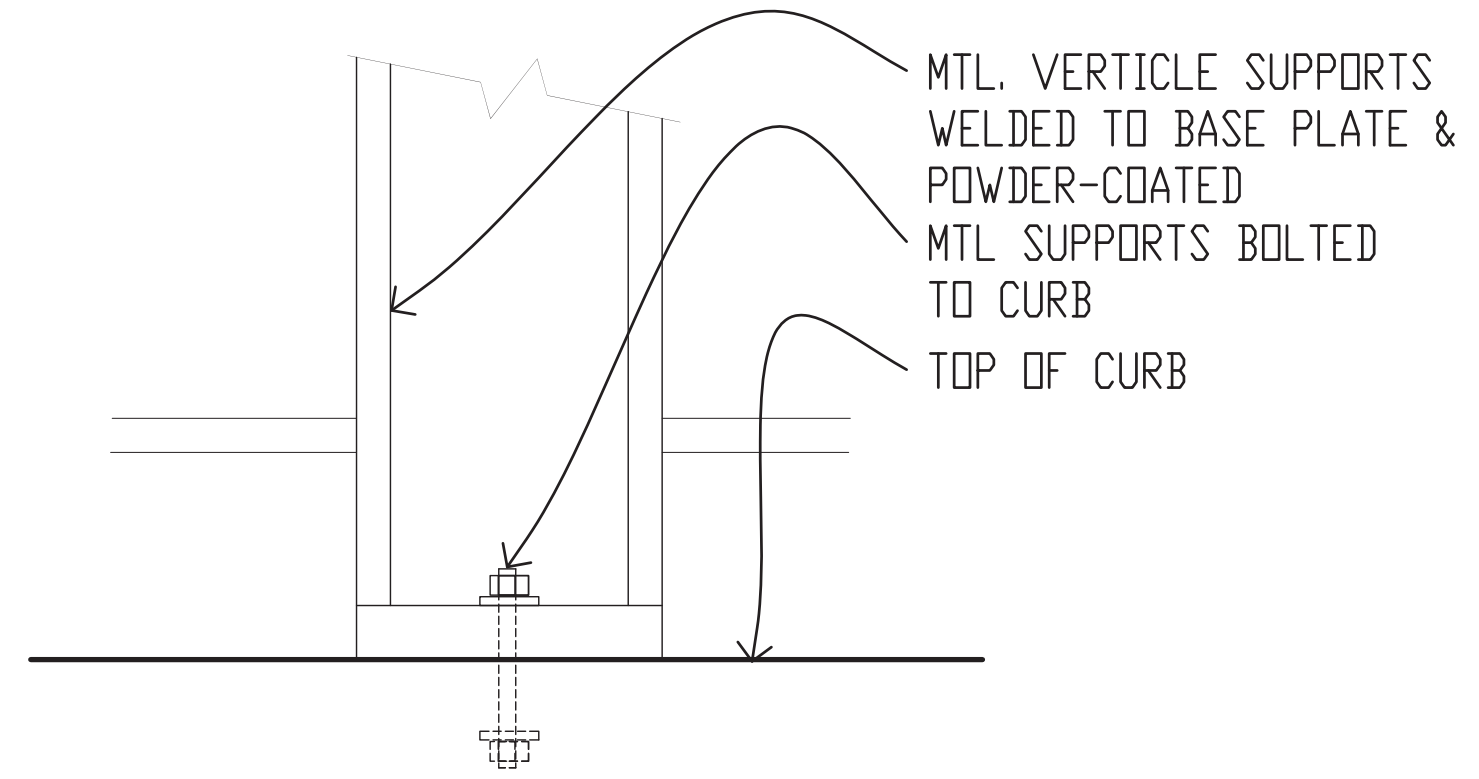

9.3 BASE DETAIL @ DINING FLOOR
3" = 1'-0"

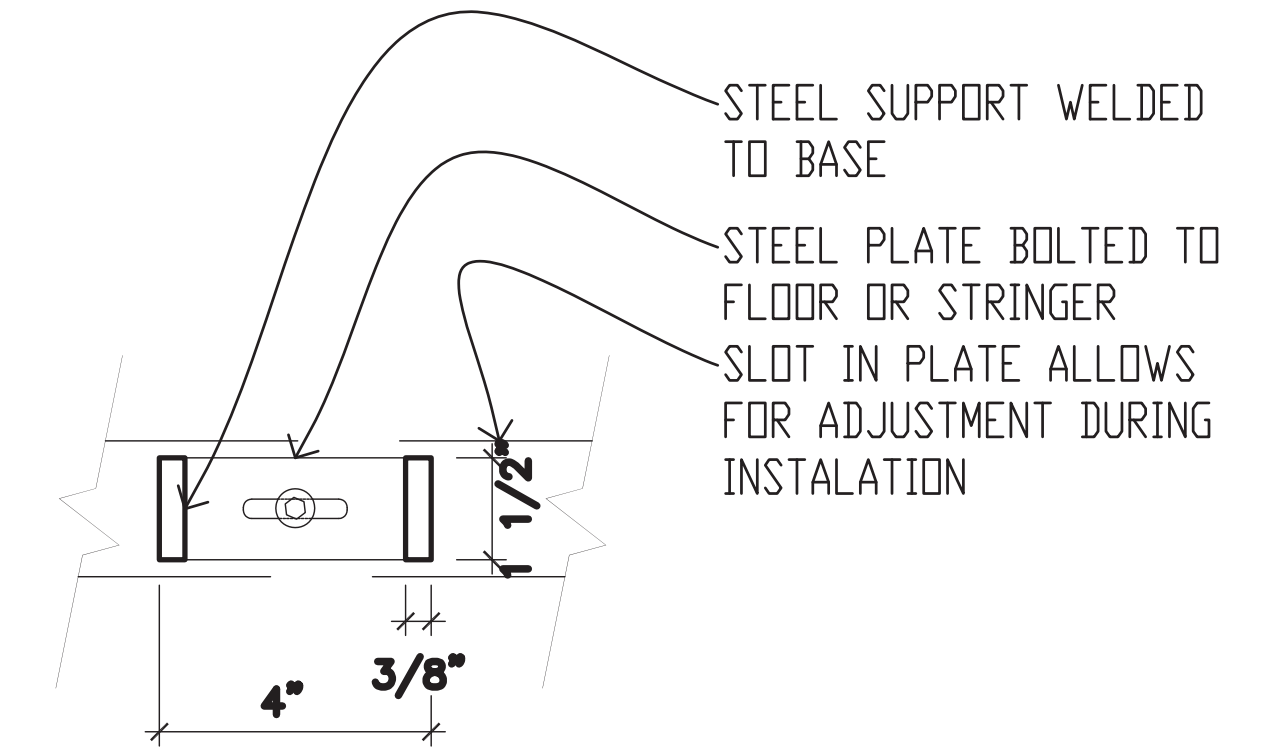

9.2 RAIL SUPPORT, TYP
3" = 1'-0"

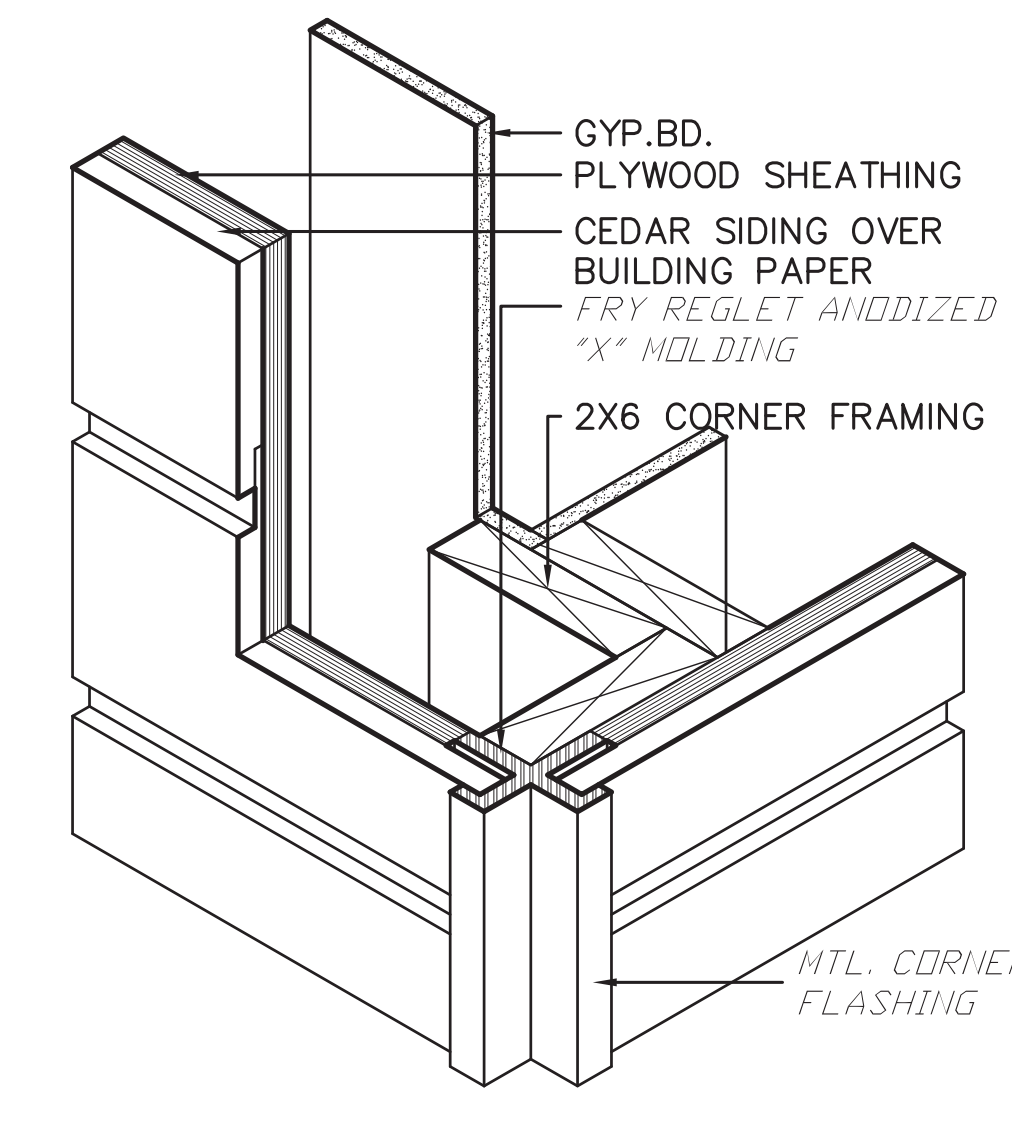

4 WOOD SIDING CORNER DETAIL
3" = 1'-0"

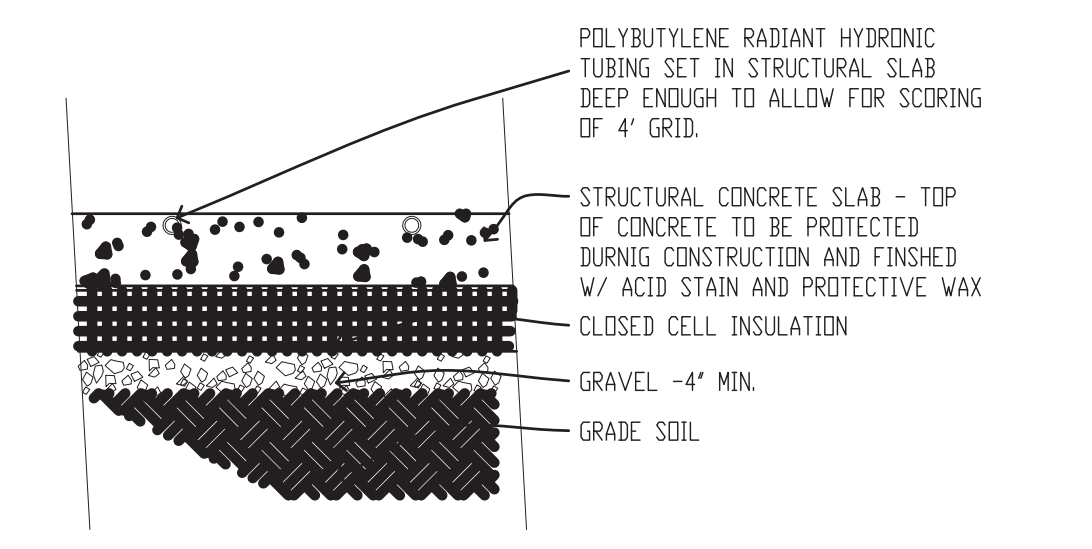

3 RADIANT HEAT SLAB
3/4" = 1'-0"

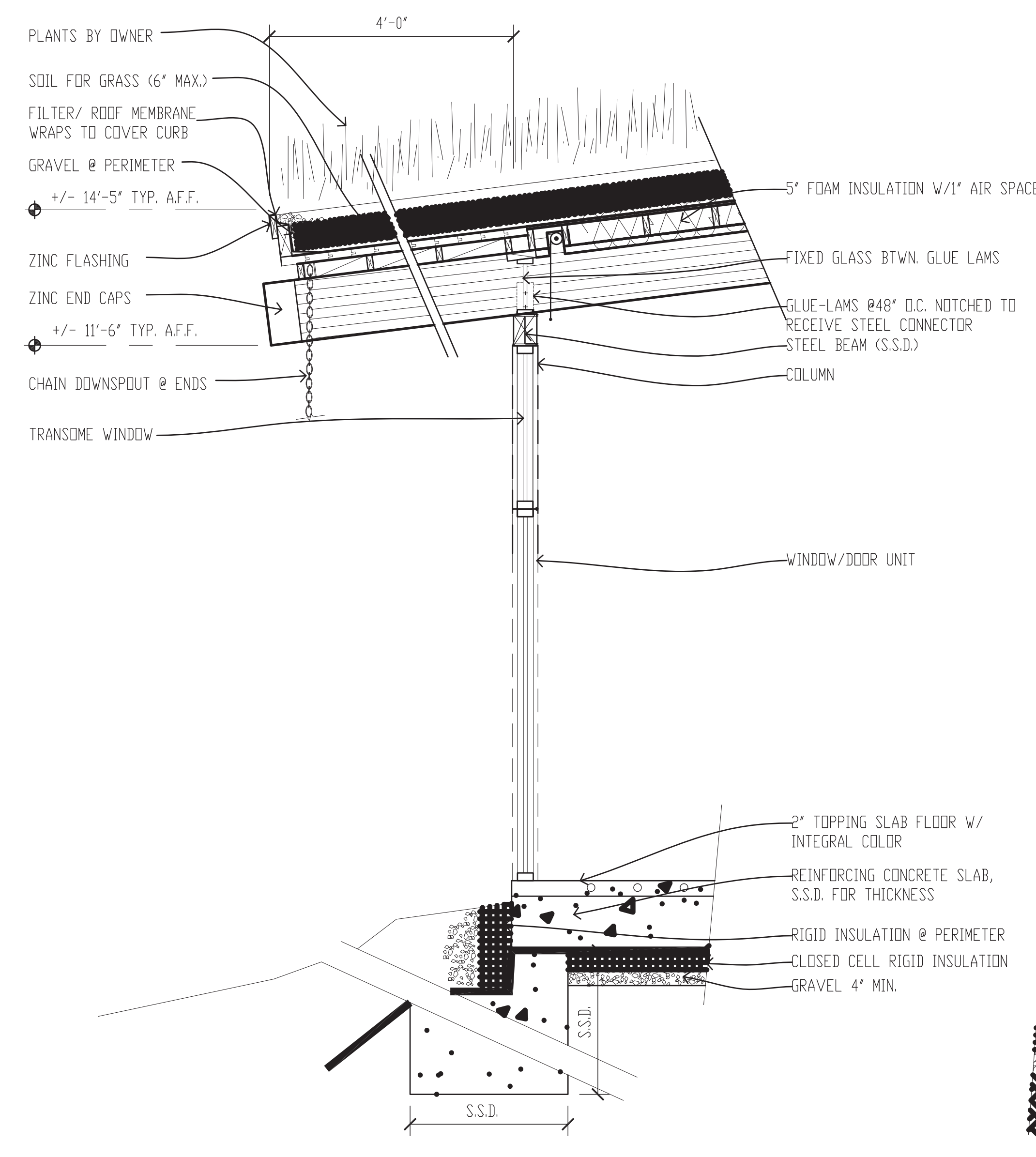

2 WINDOW WALL SECTION @ LIVING ROOM
1 1/2" = 1'-0"

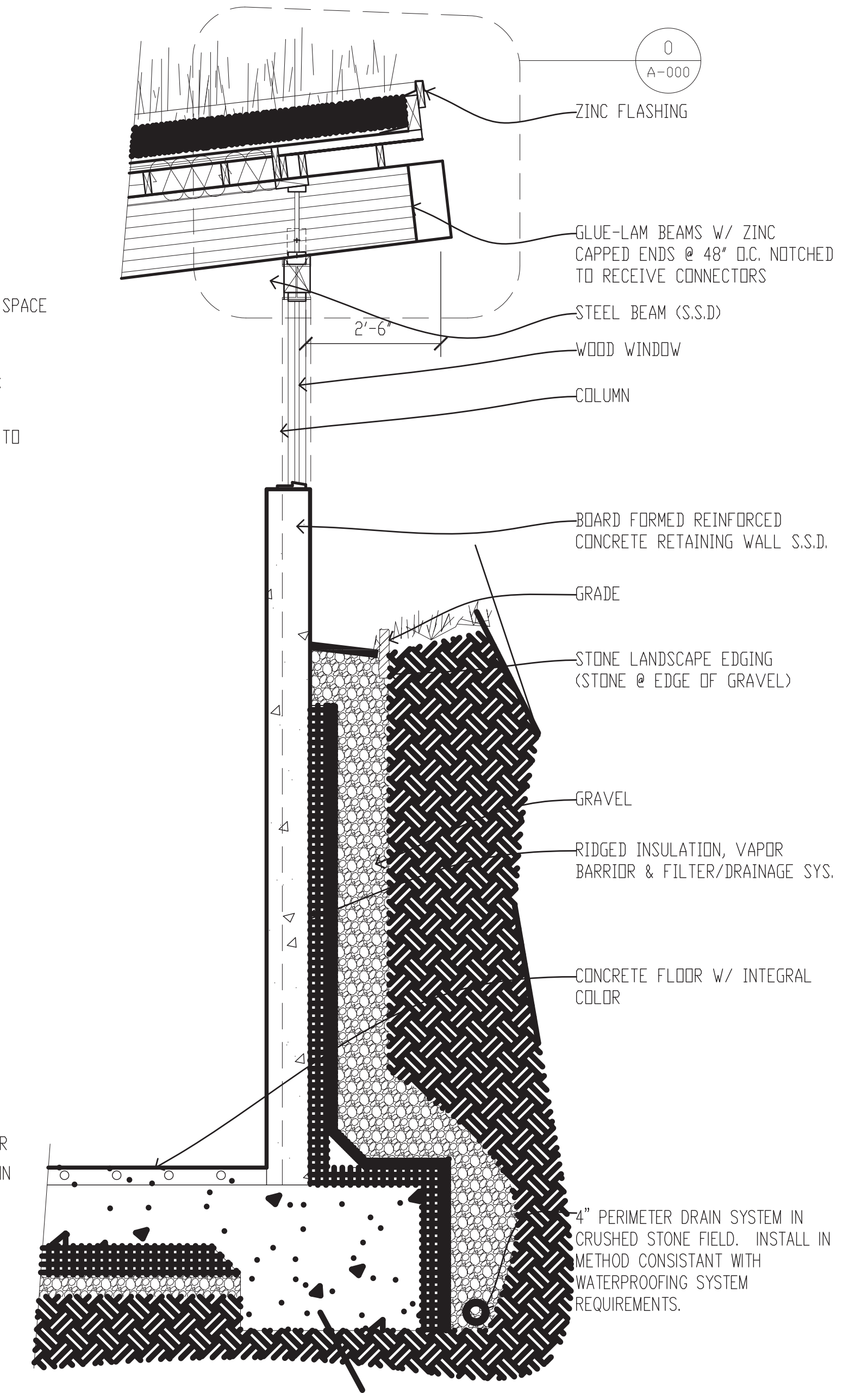

1 RETAINING WALL SECTION @ LIVING ROOM
1 1/2" = 1'-0"