

# Revised Builder's Guide to Frost Protected Shallow Foundations



September 2004

## Disclaimer

Neither the NAHB Research Center, Inc., nor any person acting in its behalf, makes any warranty, express or implied, with respect to the use of any information, apparatus, method, or process disclosed in this publication or that such use may not infringe privately owned rights, or assumes any liabilities with respect to the use of, or for damages resulting from the use of, any information, apparatus, method, or process disclosed in this publication, or is responsible for statements made or opinions expressed by individual authors.

## Acknowledgements

This guide is intended to simplify the design and construction of frost protected shallow foundations (FPSFs) and promote their widespread use. The underlying data was obtained from National Association of Home Builders (NAHB) members who provided demonstration sites for evaluation of the performance of FPSFs. Richard Morris, of the NAHB, initiated and facilitated the technology transfer into the United States and its acceptance into U.S. model building codes. The U.S. Department of Housing and Urban Development (HUD) has provided continuing support in the effort to advance the use of FPSFs.

We acknowledge the American Society of Civil Engineers' (ASCE) for permission to publish values that are contained in Tables 4 and A1 in *SEI/ASCE 32-01, Design and Construction of Frost-Protected Shallow Foundations*, 2001, authored and published by the ASCE.

This guide represents the efforts of numerous contributors over a period of more than ten years. NAHB Research Center staff members, Jay Jones, P.E., Marie Del Bianco, G. Robert Fuller, P.E. and Edith Crane amended and edited this version.

NAHB Research Center, Inc.  
Upper Marlboro, MD

# CONTENTS

<b>INTRODUCTION .....</b>	<b>1</b>
Background .....	1
<b>DESIGN PROCEDURE .....</b>	<b>4</b>
Applications/Limitations .....	4
Insulation Selection .....	4
Simplified FPSF Design Method – Heated Buildings .....	6
Detailed FPSF Design Method – Heated Buildings .....	10
Design Steps – Detailed FPSF Design Method for Heated Buildings .....	12
Detailed FPSF Design Method – Unheated Buildings .....	17
Design Steps – Detailed FPSF Design Method for Unheated Buildings .....	18
<b>CONSTRUCTION METHODS AND DETAILS .....</b>	<b>20</b>
General .....	20
Brick veneer .....	20
Cold bridges, prevention .....	21
Drainage .....	21
Energy efficiency .....	22
Excavation .....	22
Foundation height .....	22
Freeze protection during construction .....	22
Heated slabs .....	22
Landscaping and horizontal insulation .....	22
Insulation protection .....	22
Monolithic Slab .....	23
Independent Slab and Stem Wall .....	23
Unventilated Crawlspace .....	25
Unheated Areas in Otherwise Heated Buildings .....	25
<b>APPENDIX I .....</b>	<b>27</b>
Sources for Polystyrene Foam Insulation Protective Coatings	
<b>APPENDIX II .....</b>	<b>28</b>
Common Questions and Answers about FPSFs	
<b>APPENDIX III .....</b>	<b>31</b>
Building Material R-Values	
<b>APPENDIX IV .....</b>	<b>32</b>
Insulation Requirements for Energy Conservation	
<b>REFERENCES .....</b>	<b>34</b>

# LIST OF TABLES AND FIGURES

## LIST OF TABLES

Table 1.	Building Classification Based on Indoor Air Temperature (T) .....	4
Table 2.	Design Values for FPSF Insulation Materials .....	5
Table 3.	Minimum Insulation Requirements for FPSFs in Heated Buildings – Simplified Method .....	7
Table 4.	Minimum Thermal Resistance of Vertical Wall Insulation ( $R_v$ ) .....	15
Table 5.	Foundation Depths .....	15
Table 6.	Minimum Thermal Resistance of Horizontal Insulation along Walls ( $R_{hw}$ ) .....	16
Table 7.	Minimum Thermal Resistance of Horizontal Insulation at Corners ( $R_{hc}$ ) .....	16
Table 8.	Minimum Values for Design of FPSFs in Unheated Buildings .....	19
Table 9.	Nominal Thermal Resistance of Common Materials .....	31
Table 10.	Insulation Requirements for FPSFs vs. Insulation Requirements for Energy Conservation in Heated Buildings .....	33

## LIST OF FIGURES

Figure 1.	Sections of Foundation Types .....	1
Figure 2.	Frost Penetration into the Ground Under Various Conditions .....	2
Figure 3.	Frost Protected Shallow Foundation Heat Flow Diagram for a Heated Building .....	3
Figure 4.	Air-Freezing Index Map (Estimated 100 Year Return Period) .....	6
Figure 5.	FPSF Simplified Design Parameters – Heated Buildings .....	8
Figure 6.	FPSF Detailed Design Parameters – Heated Buildings .....	11
Figure 7.	FPSF Detailed Design Parameters – Unheated Buildings .....	17
Figure 8.	Brick Veneer Application .....	20
Figure 9.	Typical Illustrations of Cold Bridges .....	21
Figure 10.	Typical FPSF Monolithic Slab .....	23
Figure 11.	Independent Block Stem Wall .....	24
Figure 12.	Typical Permanent Wood FPSF .....	24
Figure 13.	Typical Unventilated Crawlspace .....	25
Figure 14.	Typical Detail for Unheated Area .....	26
Figure 15.	Typical Detail at Garage (FPSF Adjacent to Conventional) .....	26

## Background

A frost protected shallow foundation (FPSF) is a practical alternative to a deeper, more-costly foundation in cold regions with seasonal ground freezing and the potential for frost heave. The International Residential Code® (IRC) includes prescriptive methods for constructing frost protected shallow foundations in heated buildings. By the IRC reference to ASCE 32-01 (American Society of Civil Engineers, *Design and Construction of Frost-Protected Shallow Foundations*, 2001), FPSFs in semi-heated and unheated buildings that meet the requirements of the IRC may also be designed and constructed.

Figure 1 shows an example of a frost protected shallow foundation and a conventional foundation designed for a climate with an Air-Freezing Index (AFI) of 2,000°F with a 100-Year Return (winter) Period. An FPSF incorporates strategically placed insulation to raise soil temperature and the frost depth around a building, thereby allowing foundation depths as shallow as 16 inches for almost all areas of the continental U.S. The objective of this design guide is to assist U.S. residential building industry stakeholders in the design, construction, and code approval of frost protected shallow foundations.

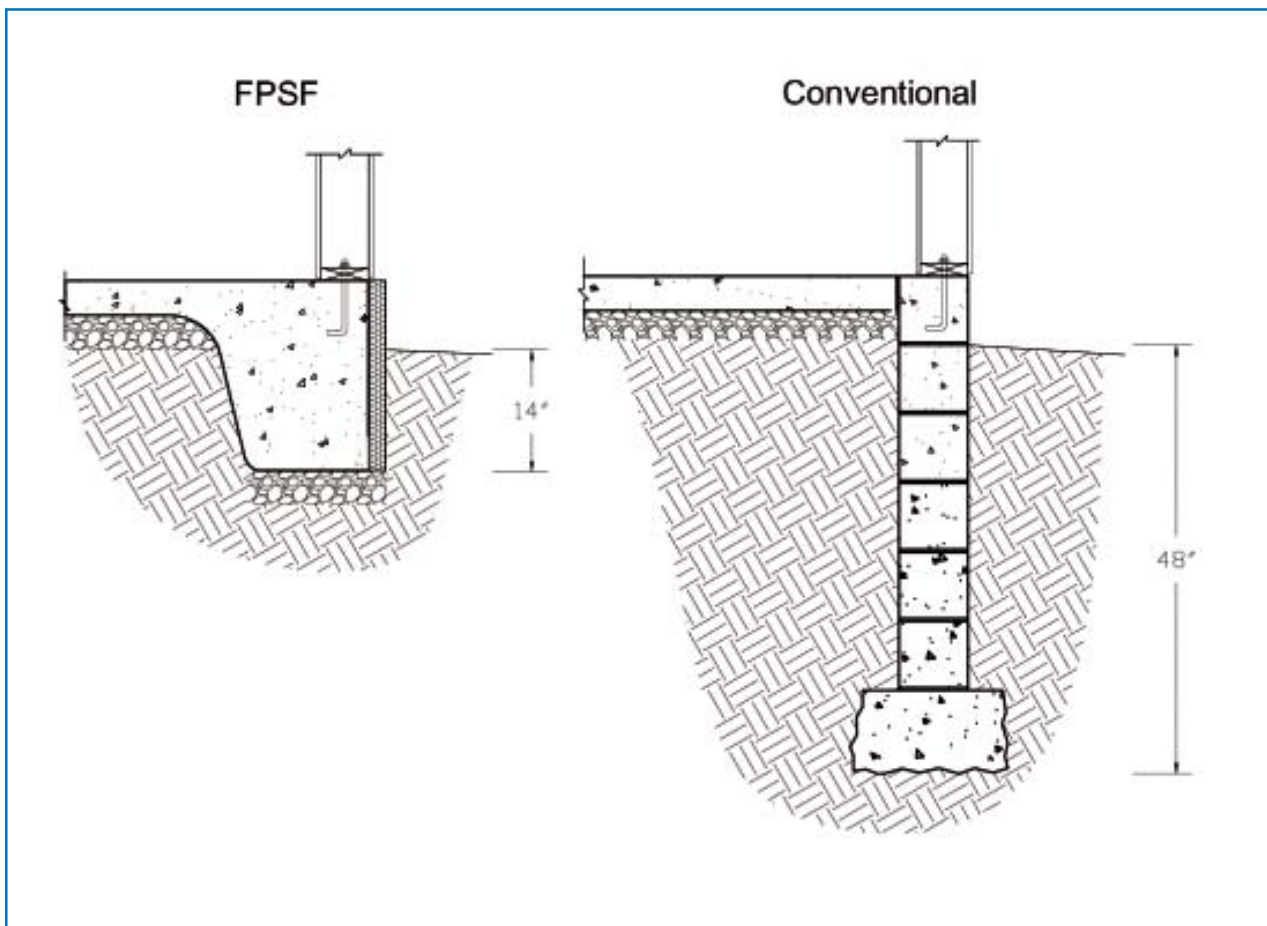
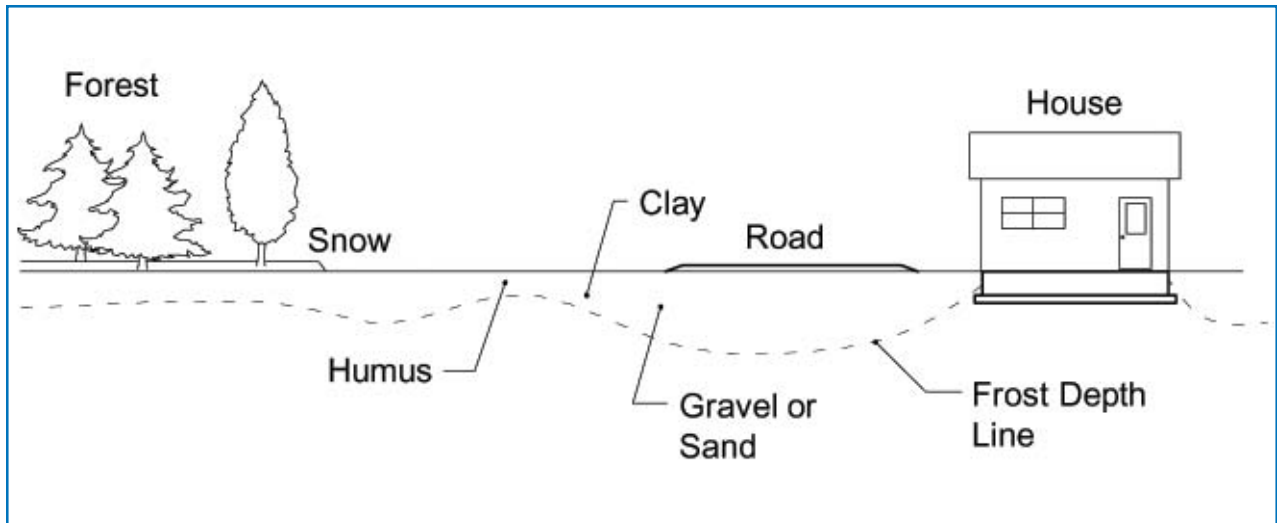

Figure 1. Sections of Foundation Types

A frost protected shallow foundation allows builders to construct a structurally sound foundation that is more resource efficient and less costly than a conventional foundation. The FPSF technology recognizes the thermal interaction of building foundations with the ground. Heat input to the ground from a conditioned building effectively raises the frost depth at the perimeter of the foundation. This effect and other conditions that regulate frost penetration into the ground are illustrated in Figure 2.



**Figure 2. Frost Penetration into the Ground Under Various Conditions**

The effect of heat from the building is magnified when insulation is strategically placed around the foundation. Frost protection of an insulated foundation also works for an unheated building by conserving ground geothermal heat beneath the building. Unheated areas of homes, such as garages, may be constructed in this manner.

Figure 3 illustrates the heat exchange process in an FPSF, which results in a shallower frost penetration depth around the building due to soil that has been warmed by both building and geothermal heat. The insulation around the foundation perimeter conserves and redirects heat loss through the slab toward the soil below the foundation. Geothermal heat from the underlying ground also helps to warm the soil and raise the frost depth around the building.

Frost protected shallow foundations are most suitable for slab-on-grade homes on sites with moderate to low sloping grades. Slab-on-grade FPSFs can be installed with one placement of concrete, eliminating multiple inspections and speeding construction time. The method may also be used effectively with walkout basements by insulating the foundation on the downhill side of the house. Frost protected shallow foundations are also useful for remodeling projects because their installation minimizes site disturbance. In addition to residential, commercial, and agricultural buildings, the technology has been applied to highways, dams, underground utilities, railroads, and earth embankments.

This document presents an FPSF design procedure for slab-on-grade, stem wall foundations, and unventilated crawlspace foundations, and includes design examples, and specific construction methods and details. Additionally, a simplified design method adopted by the IRC is presented.

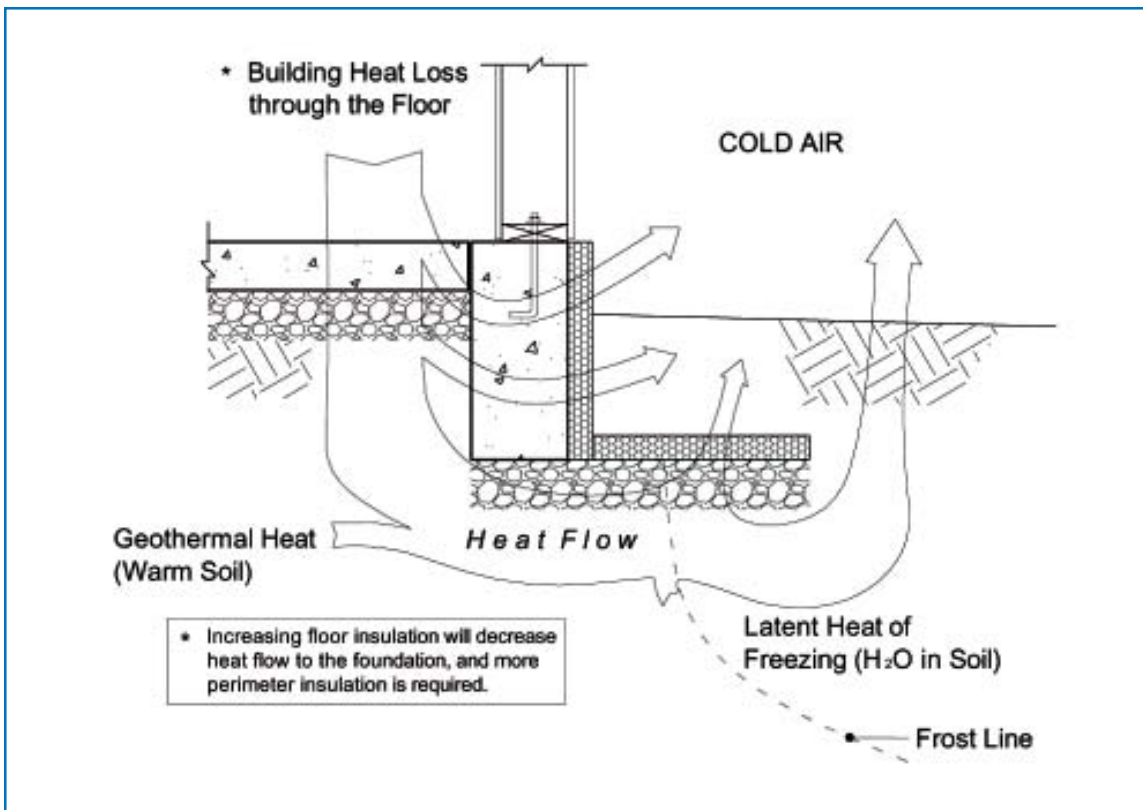

Figure 3. Frost Protected Shallow Foundation Heat Flow Diagram for a Heated Building

## Applications/Limitations

This procedure addresses the design of frost protected shallow foundations that incorporate polystyrene foam insulation to prevent frost heave in cold climates. It was developed for slab-on-grade, stem wall, and unvented crawlspace foundations of residential homes, but may also be used on commercial and agricultural structures.

This design procedure does not apply to buildings on permafrost or to areas with mean annual temperatures less than 32°F (0°C). Also, the significant cost savings for Frost Protected Shallow Foundations afforded in the Northern United States will not be achieved in areas where the Air-Freezing Index is very low — the Southern tier of states. In addition, use of below-ground foam plastics over the foundation requires use of termite protection appropriate to the termite threat in the region in which built. Below-ground foam is not currently recommended in areas of “very heavy termite infestation probability” — South Carolina, Georgia, Florida, Alabama, Mississippi, Louisiana, the eastern half of Texas, and most of California — unless special provisions are followed.

This guide contains two approaches: a simplified design and a detailed design. The simplified method streamlines the design and material selection process of FPSFs for heated buildings. The simplified design procedure is adopted by the model building codes. In consolidating the design steps for the simplified method, R-values for insulation were established so that performance levels under various conditions and slab surface temperatures are conservatively accommodated. Therefore, more economical construction may be obtained when detailed design procedures are followed. The detailed design procedure should be used when buildings include unheated areas such as attached garages, unless conventional footings are used for the garage.

Design methods specify thermal resistances and foundation depths that ensure protection against frost heave damage in most types of soils. The methods are conservative in that they assume a 100 year return winter, with no insulating ground vegetative or snow cover. This guide addresses heated structures with attached, unheated garages, as defined by the expected average indoor monthly temperature range (Table 1). Guidance for design of FPSFs in semi-heated buildings (41°F-63°F) is available in ASCE 32-01.

**Table 1. Building Classification Based on Indoor Air Temperature (T)**

Minimum Average Monthly Indoor Temperature, T	Classification	Typical Type of Structure
T > 64°F (18°C)	Heated	Homes
T < 41°F (5°C)	Unheated	Garages

## Insulation Selection

The proper specification of insulation products is paramount to the success of an FPSF application. Insulation products are classified by an R-value for above ground dry conditions. For below ground application, products specified must perform in the moist environment for the expected life of the structure, so an effective R-value is calculated.



In addition to proper insulation material selection, a definitive primary path for shedding water over the grade and away from the foundation needs to be established to minimize sub-surface water collecting at the foundation.<sup>1</sup>

Insulation for below ground, frost protection applications in the U.S. shall comply with ASTM C 578, *Standard Specification for Rigid, Cellular Polystyrene Thermal Insulation*. The standard does not provide for potential degradation of the material's thermal resistance in moist, below grade conditions, so accepted design values for FPSF insulation materials were conservatively calculated to be approximately 10% less than the nominal R-value for extruded polystyrene (XPS) and 20% less than nominal values for expanded polystyrene (EPS), in a vertical application. Design values for polystyrene foam are represented in Table 2. The highlighted columns, 5v and 5h, represent the effective values to be used when calculating the FPSF insulation.

**Table 2. Design Values for FPSF Insulation Materials<sup>1</sup>**

Type of Polystyrene Foam	Type of Insulation	Minimum density (pcf)	Nominal R-value (per inch)	Max. Effective R-value (per inch)		Allowable Bearing Capacity <sup>2</sup> (psf)	Minimum Thickness (inches)	
				5v	5h		7v	7h
1	2	3	4	Vertical	Horizontal	6	Vertical	Horizontal
Expanded (EPS)	II	1.35	4.0	3.2 <sup>3</sup>	2.6 <sup>3</sup>	-	2.0	3.0
Expanded (EPS)	IX	1.8	4.2	3.4 <sup>3</sup>	2.8 <sup>3</sup>	1,200	1.5	2.0
Extruded (XPS)	IV	1.6	5.0	4.5	4.0	1,200	1.0	1.5
Extruded (XPS)	V	3.0	5.0	4.5	4.0	4,800	1.0	1.0
Extruded (XPS)	VI	1.8	5.0	4.5	4.0	1,920	1.0	1.0
Extruded (XPS)	VII	2.2	5.0	4.5	4.0	2,880	1.0	1.0
Extruded (XPS)	X	1.35	5.0	4.5	4.0	-	1.5	2.0

<sup>1</sup> Per ASTM C578, except for effective R-values (shaded column).

<sup>2</sup> Bearing capacity developed for non-cyclic loading conditions at 10% deformation.

<sup>3</sup> SEI/ASCE 32-01 adopted values and restrictions are referenced. Reprinted with permission, American Society of Civil Engineers, "Design and Construction of Frost-Protected Shallow Foundations," 2001. <http://www.PUBS.ASCE.org>

<sup>1</sup> For additional information on envelope detailing and site grading at foundation perimeter see *Durability by Design, A Guide for Residential Builders and Designers*, NAHB Research Center for PATH. (May 2002.) <http://www.huduser.org/publications/destech/durdesign.html>

## Simplified FPSF Design Method – Heated Buildings

To use the simplified approach, the Air-Freezing Index (AFI) for the site location must be known. The AFI is an indicator of the combined duration and magnitude of below-freezing temperature occurring during any given freezing season. An AFI contour map is provided in Figure 4 to assist in establishing this value. Detailed information can be found in the IRC® or the National Climate Center (NCDC) website referenced by Figure 4.

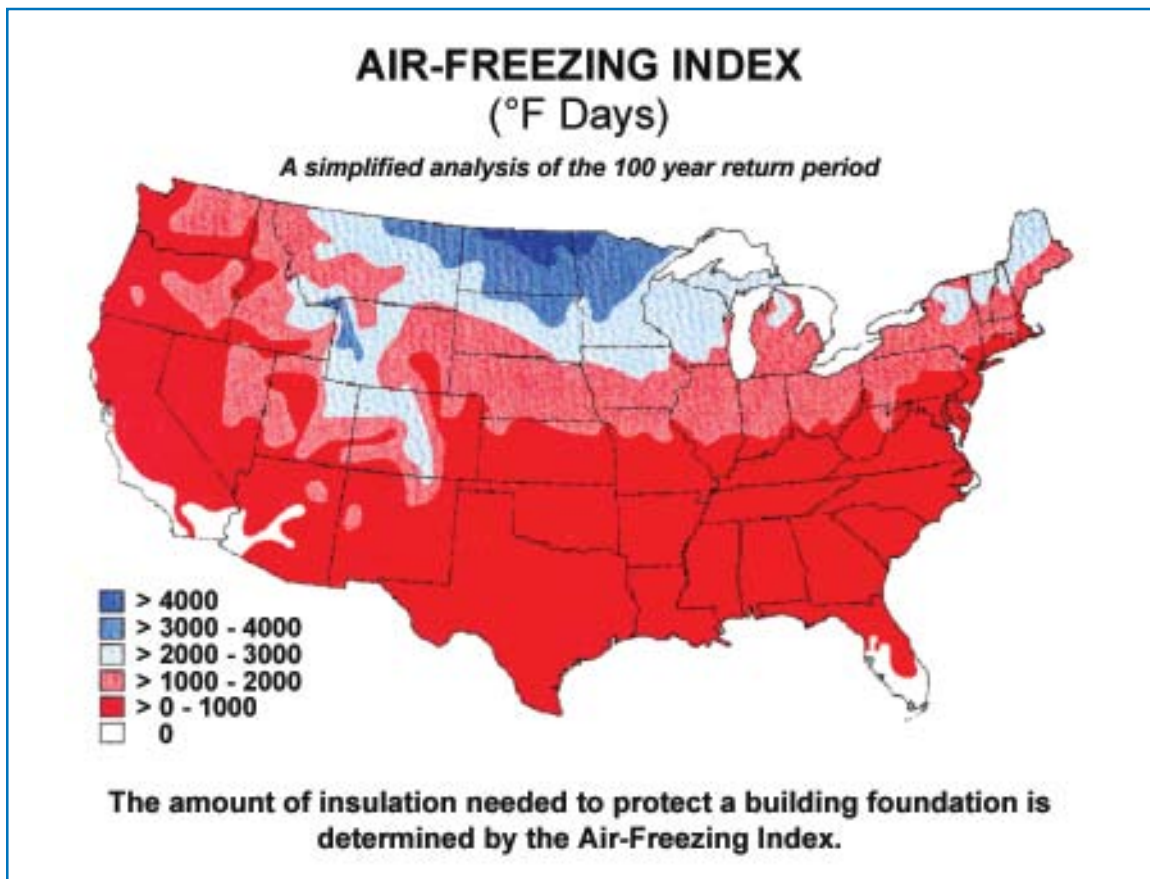

**Figure 4. Air-Freezing Index Map (Estimated 100 Year Return Period)**

Source: <http://wfw.ncdc.noaa.gov/oa/fpsf>

Insulation R-value, dimensions, and depth of footings are then determined from Table 3, based on the AFI. These minimum requirements for perimeter insulation of an FPSF are divided by the effective values presented in Table 2 for specification of insulation type and thickness. Because the FPSF relies, in part, on the building's heat to effectively raise the frost depth of the adjacent soil, slabs or floor assemblies of heated buildings designed by the Simplified Method shall be designed with an R-value less than 10.

**Table 3. Minimum Insulation Requirements for FPSFs in Heated Buildings<sup>1</sup>  
– Simplified Method**

Air Freezing Index (°F <sub>100</sub> ) <sup>2</sup>	Vertical Insulation R-Value <sup>3,4</sup>	Horizontal Insulation R-Value <sup>3,5</sup>		Horizontal Insulation Dimensions per Figure 5. (in inches)			Minimum Footing Depth (in inches)
		Along Walls	At Corners	A	B	C	
≤1,500	4.5	NR	NR	NR	NR	NR	12
2,000	5.6	NR	NR	NR	NR	NR	14
2,500	6.7	1.7	4.9	12	24	40	16
3,000	7.8	6.5	8.6	12	24	40	16
3,500	9.0	8.0	11.2	24	30	60	16
4,000	10.1	10.5	13.1	24	36	60	16
4,500	12.0	12.0	15.0	36	48	80	16

<sup>1</sup> Insulation requirements are for protection against frost damage in heated buildings. Greater values may be required to meet energy conservation standards. See Appendix IV.

<sup>2</sup> See Figure 4 for Air Freezing Index values.

<sup>3</sup> Insulation materials shall provide the stated minimum R-values under long-term exposure to below ground conditions in freezing climates. NR indicates that insulation is not required.

<sup>4</sup> Vertical insulation shall be expanded polystyrene insulation or extruded polystyrene insulation.

<sup>5</sup> Horizontal insulation shall be extruded polystyrene insulation.

<sup>6</sup> Interpolation between values is permissible.

<sup>7</sup> Portions of Table 3 reprinted with permission from SEI/ASCE 32-01, American Society of Civil Engineers, "Design and Construction of Frost-Protected Shallow Foundations," 2001. <http://www.PUBS.ASCE.org>

Figure 5 contains a section and plan view of the possible insulation locations for FPSFs dependant on climate zone of project. The alphabetical characters in Figure 5 correspond to the identically designated columns in Table 3.

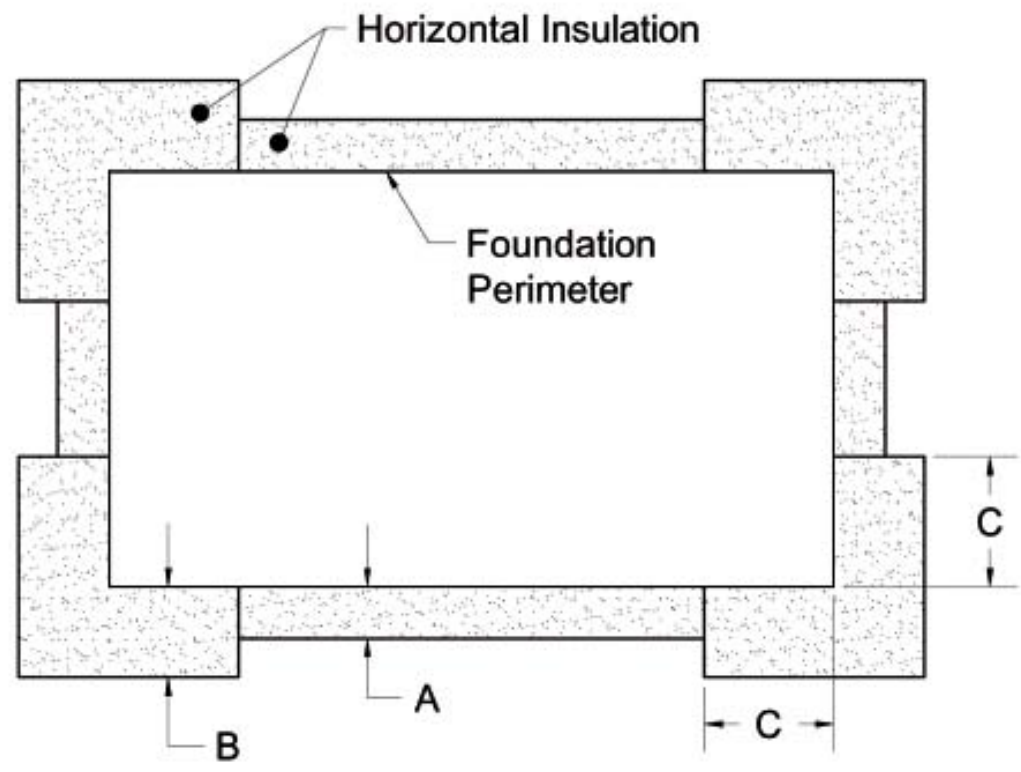
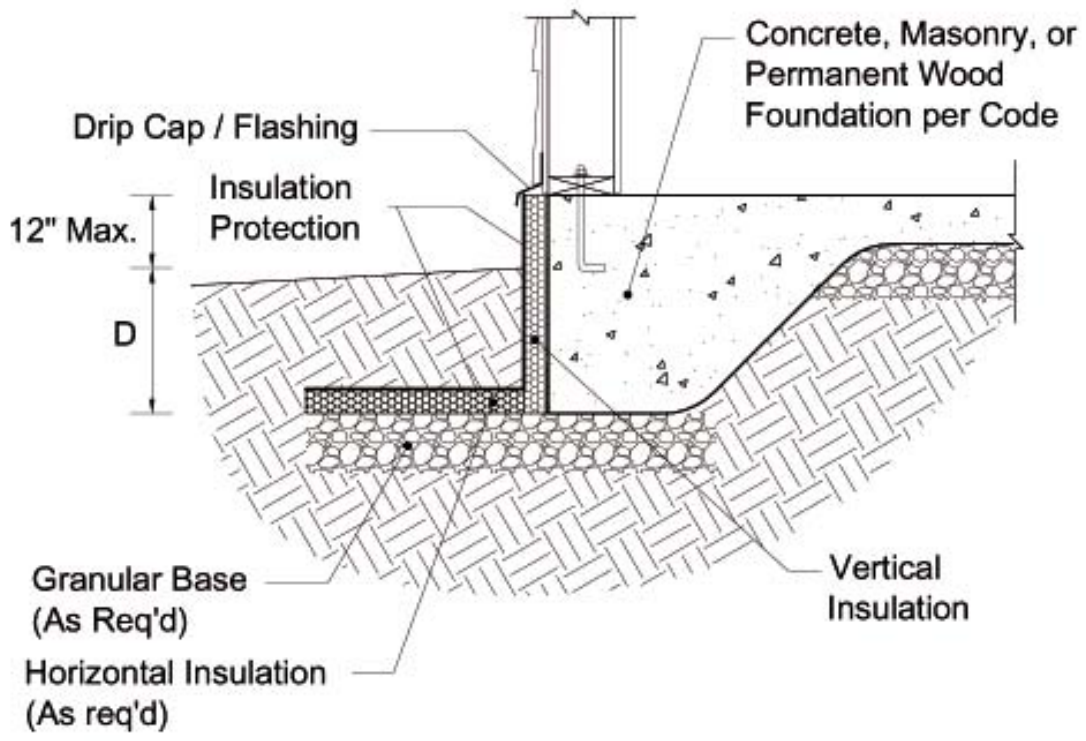

Figure 5. FPSF Simplified Design Parameters – Heated Buildings

To illustrate the simplified design method, a northern Michigan location lying within a 2,000 AFI contour (from Figure 4) is the selected site location. Table 3 indicates that the vertical insulation R-value for a FPSF in this area where the AFI  $\leq 2,000$  is R - 5.6. Table 3 also indicates that horizontal insulation is not required and the footing depth should be 14 inches.

The minimum insulation value (R-5.6) is divided by the effective R-value of the selected type of insulation in Table 2, column 5v, to determine the required minimum thickness of insulation. If XPS is used, a 1 1/2" thickness will yield an effective R-value of 6.75. If available, 1 1/4" thick XPS would be adequate. If EPS is used, a 2" thickness will yield an effective R-value of 6.4 or 6.8. If available, 1 3/4" thickness of either Types II or IX EPS would be adequate.

Consult product manufacturers for foam cost and availability. Typical sheet sizes are 2' x 8' and 4' x 8' in thickness increments of 1/2", from 1" to 3" total thickness.

While not a detail of the design used in this example, horizontal insulation (if required) should be bedded firmly on smooth ground or granular base and buried a minimum of 12" below ground surface or protected with suitable coating. Horizontal insulation that extends more than 24" must be protected by a hard surface with backfill carefully placed to assure positive drainage of water away from foundation. Vertical insulation requires a protective coating where exposed above grade and for 6" below finish grade. Appendix I contains information on protective materials.

When footing depths greater than 12" are required, the increase in depth may be satisfied by substituting compacted gravel, crushed rock, sand, or other approved non-frost susceptible materials.

Table 10 in Appendix IV compares the minimum perimeter (vertical) R-values required for FPSF design with the minimum values required by current energy conservation codes for conventional foundations. In most areas where the AFI is 1,500 or higher, the energy code requires a minimum R-value for slab insulation that is higher than the minimum R-value for an FPSF design. This means two things — a design that meets FPSF requirements may need even more insulation to meet energy code and conventional foundations that are insulated to meet the energy code could have been built as an FPSF design (with the attendant concrete and excavation savings).

## Detailed FPSF Design Method – Heated Buildings

There are many different combinations of vertical and horizontal insulation details, R-values, and footing depths that can be used in an FPSF. The detailed design approach is a flexible approach that allows the designer to utilize experience and select the preferred method of construction for a given site. For example, the designer may opt to provide vertical wall insulation only, horizontal insulation only at the corners, or provide horizontal insulation around the entire building. The designer also has the flexibility to increase foundation depths, add horizontal insulation to reduce required foundation depths, or select the width of horizontal insulation to meet minimum requirements.

Figure 6 illustrates the parameters for detailed FPSF design. The Steps that follow Figure 6 outline the detailed design method for heated buildings. Tables 4, 5, 6 and 7 follow these Steps and provide the selections that are possible for the parameters defined in Figure 6.

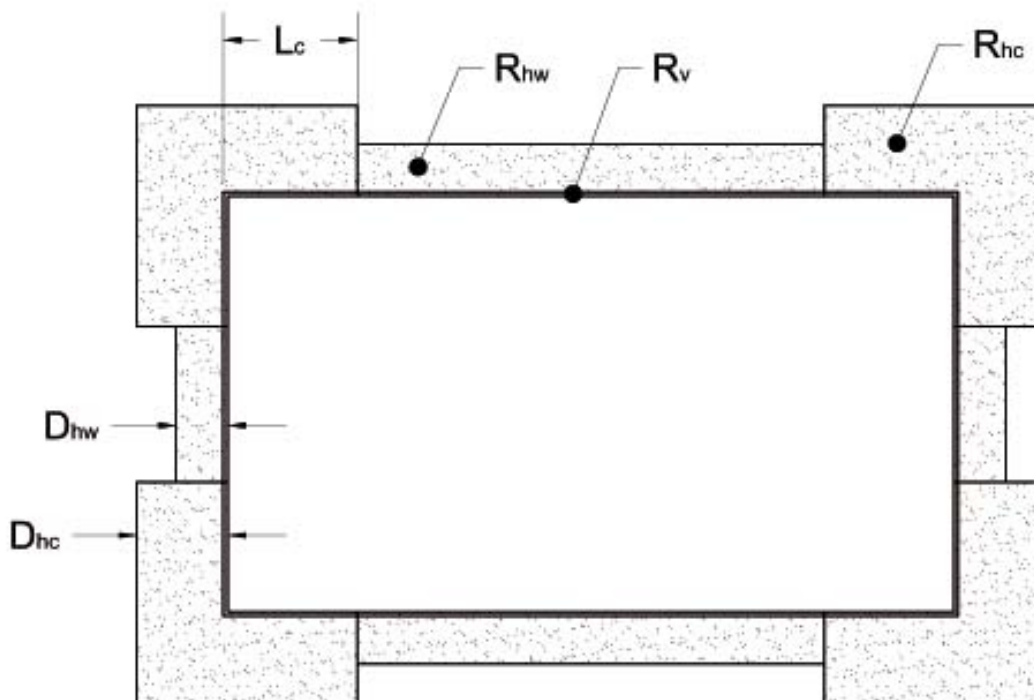
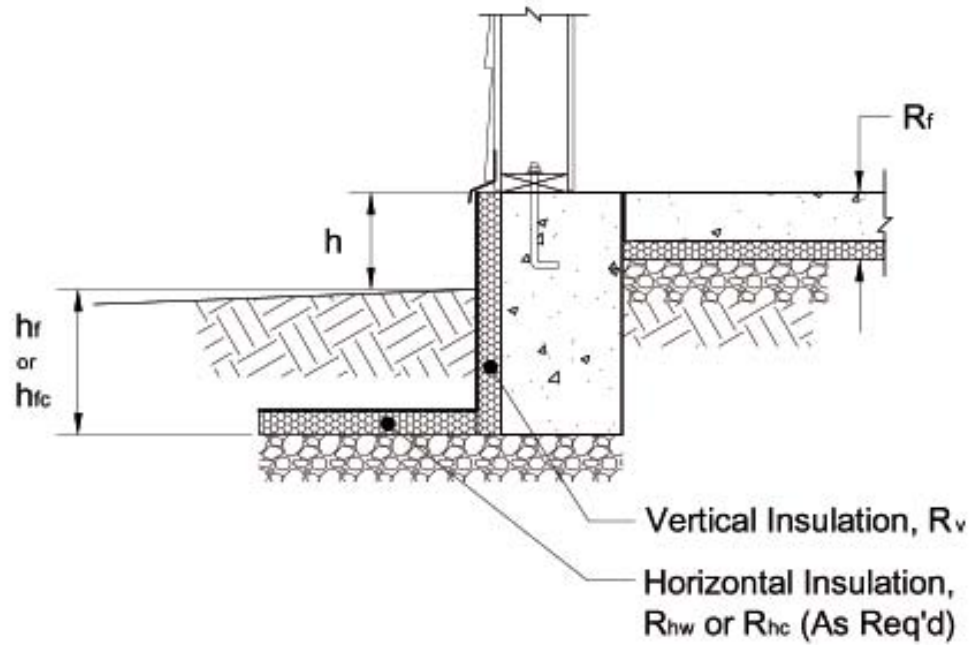

Figure 6. FPSF Detailed Design Parameters – Heated Buildings

## Design Steps – Detailed FPSF Design Method for Heated Buildings

### Step 1: Determine the Site's Design Air Freezing Index, AFI

Select the 100 year return period design air freezing index, AFI, from Figure 4. The AFI values are conservative because they are not adjusted for the insulating benefit of a normal snow cover on the ground. A lower return period value may be used for less important structures or those that are resilient to infrequent ground freezing. See NOAA website, <http://lwf.ncdc.noaa.gov/oa/fpsf>, for values at return periods less than 100 years.

AFI = \_\_\_\_\_

### Step 2: Calculate the R-value of the Floor System Cross Section, $R_f$

Calculate the thermal resistance of the floor system,  $R_f$  from Figure 6, considering all insulating materials in the cross-section including any floor coverings. When determining  $R_f$ , nominal R-values shall be used for all materials, including insulation. (Use the aggregate of manufacturer's nominal values for each component of the floor system. Some common materials and R-values are contained in Appendix III.) If the floor cross-section and resulting thermal resistance of the floor system varies over its area, calculate  $R_f$  as the average over the perimeter 39 inches (1m) of the floor. In superinsulated slabs, where the calculated  $R_f$  value exceeds R-28, the designer must follow the design procedure for unheated buildings, since the heat from the building is substantially blocked from moving into the ground and protecting the foundation.

$R_f$  = \_\_\_\_\_

### Step 3: Determine the Required R-value of Vertical Wall Insulation, $R_v$

Determine the minimum required thermal resistance of the vertical wall insulation,  $R_v$ , from Table 4, given the foundation height above grade,  $h$  from Figure 6, the AFI from Step 1, and  $R_f$  from Step 2.

$h$  = \_\_\_\_\_

$R_v$  = \_\_\_\_\_

### Step 4: Select Vertical Wall Insulation

Based on the required  $R_v$  value from Step 3, select an adequate thickness of vertical XPS or EPS insulation using the effective R-values from Table 2, column 5v. Common nominal thicknesses are 1", 1-1/2", and 3". The insulation shall extend from the bottom of the footing to the exterior wall envelope as shown in Figure 6.

$R_v$  = \_\_\_\_\_ = \_\_PS Type\_\_ at \_\_\_\_\_" thickness.



(Thickness =  $R_v$  divided by effective R-value)

**Step 5: Select Foundation Depth or Horizontal Insulation,  $h_f$ ,  $D_{hw}$  and  $R_{hw}$**

Horizontal insulation is placed below ground extending outward from the vertical wall insulation as shown in Figure 6. For climates where the AFI is less than 2,250°F-days, horizontal insulation along the walls is not required and the designer may proceed to Step 7. In more severe climates, where horizontal insulation is not desired, select the minimum foundation depth,  $h_f$ , from Table 5, column 1.

When the designer desires to limit the foundation depth to 16 inches in severe climates (AFI > 2,250°F-days), select the minimum width the horizontal insulation shall extend from the foundation wall,  $D_{hw}$  from Table 6, and the required minimum thermal resistance of insulation,  $R_{hw}$  from Table 6.

$h_f =$  \_\_\_\_\_

$D_{hw} =$  \_\_\_\_\_

$R_{hw} =$  \_\_\_\_\_

**Step 6: Select Thickness of Horizontal Insulation for Walls**

Based on the required  $R_{hw}$  value determined in Step 5, select an adequate thickness of horizontal insulation using the effective resistivity values in Table 2, column 5h. Horizontal insulation must have at least 12" of ground cover and securely abut the vertical wall insulation.

$R_{hw} =$  \_\_\_\_\_ divided by \_\_\_\_\_ (effective R-value) = \_\_\_\_\_" thickness \_\_\_\_\_ PS, Type \_\_\_\_\_

**Step 7: Select Foundation Depth or Horizontal Insulation at Corners,  $h_{fc}$ ,  $D_{hc}$ ,  $D_{hw}$ ,  $R_{hc}$ ,  $L_c$ ,  $R_{hw}$**

Since more heat loss occurs at building corners than through mid-wall sections of heated buildings, additional frost protection in the form of horizontal insulation or a deeper foundation is required for more severe climates (AFI > 2,250°F-days) at the building corners. Where horizontal insulation is not desired in any climate, select the minimum foundation depth at corners,  $h_{fc}$  from column 3, Table 5.

$h_{fc} =$  \_\_\_\_\_

For a uniform foundation depth,  $h_f = h_{fc}$ , use column 5, Table 5 to determine foundation depth and install horizontal insulation at the building corners with an effective thermal resistance of 5.7 ( $R_{hc}$ ). The length and width of the horizontal corner insulation,  $L_c$  and  $D_{hc}$ , shall be consistent with columns 4 and 6 of Table 5.

$h_{fc} =$  \_\_\_\_\_

$R_{hc} =$  \_\_\_\_\_

$$D_{hc} = \underline{\hspace{2cm}}$$

$$L_c = \underline{\hspace{2cm}}$$

If it is desired to limit the foundation depth to 16 inches, select the minimum width of horizontal insulation to extend from the foundation wall,  $D_{hw}$  from Table 6, and minimum required thermal resistance of insulation,  $R_{hw}$  from the corresponding columns of Table 6. Once the required  $R_{hw}$  has been determined, select an appropriate thickness of horizontal insulation, using an effective R-value from Table 2, column 5h.

$$D_{hw} = \underline{\hspace{2cm}}$$

$$R_{hw} = \underline{\hspace{2cm}} \text{ divided by } \underline{\hspace{2cm}} \text{ (effective R-value) = } \underline{\hspace{2cm}} \text{ inches, } \underline{\hspace{2cm}} \text{ PS, Type } \underline{\hspace{2cm}}$$

Repeat these steps with the parameters pertaining to building corners in Table 8. The width and length of the corner horizontal insulation,  $D_{hc}$  and  $L_c$ , respectively, yield the necessary thermal resistance of the foam,  $R_{hc}$ .

$$D_{hc} = \underline{\hspace{2cm}}$$

$$L_c = \underline{\hspace{2cm}}$$

$$R_{hc} = \underline{\hspace{2cm}} \text{ divided by } \underline{\hspace{2cm}} \text{ (effective R-value) = } \underline{\hspace{2cm}} \text{ inches } \underline{\hspace{2cm}} \text{ PS, Type } \underline{\hspace{2cm}}$$

**Table 4. Minimum Thermal Resistance of Vertical Wall Insulation ( $R_v$ )**

AFI (°F <sub>100</sub> )	Slab or Floor Assembly R-Value ( $R_f$ )					
	0.0 < $R_f$ < 6.0		6.0 < $R_f$ < 15.0		15.0 < $R_f$ < 28.0	
	$h \leq 12$ in	$h = 24$ in	$h \leq 12$ in	$h = 24$ in	$h \leq 12$ in	$h = 24$ in
≤ 375	0.0	3.0	4.5	5.7	5.7	8.5
750	3.0	4.6	5.7	5.7	8.5	11.4
1,500	4.5	5.7	5.7	5.7	8.5	11.4
2,250	5.7	5.7	5.7	7.4	8.5	14.2
3,000	5.7	5.7	6.8	8.5	9.7	15.3
3,750	5.7	6.8	8.0	9.7	11.4	17.0
4,500	6.8	8.0	10.2	11.9	13.6	19.3

Design parameters are identified in Figure 6.

**Table 5. Foundation Depths<sup>1</sup>**

AFI (°F <sub>100</sub> )	Foundation Depth along Walls (No Horizontal Insulation)	Foundation Depth at Corners (No Horizontal Insulation)		Foundation Depth at Corners with R - 5.7 Horizontal Insulation at Corners, only		
	1	2	3	4	5	6
	$h_f$ (inches)	$L_c$ (inches)	$h_{fc}$ (inches)	$L_c$ (inches)	$h_{fc}$ (inches)	$D_{hc}$ (inches)
1,500 or less	12	—	12	—	12	—
2,250	14	—	14	—	14	—
2,625	16	40	24	40	16	20
3,000	20	40	32	40	20	20
3,375	24	60	40	60	24	20
3,750	30	60	51	60	30	24
4,125	36	60	63	60	36	32
4,500	43	80	71	80	43	32

<sup>1</sup> Without horizontal insulation or with horizontal insulation at corners only.  
Design parameters are identified in Figure 6.

**Table 6. Minimum Thermal Resistance of Horizontal Insulation along Walls ( $R_{hw}$ )<sup>1</sup>**

AFI (°F <sub>100</sub> )	R-Values at Various Widths, $R_{hw}$							Footing Depth
	Width of Horizontal Insulation, $D_{hw}$ (in inches)							
	12"	18"	24"	30"	36"	42"	48"	
≤ 2,250	0.0							16"
2,625	2.5							16"
3,000	6.5	6.1	5.3	4.5				16"
3,375		8.2	7.4	6.5				16"
3,750			9.1	8.5	7.7			16"
4,125			11.2	10.2	9.6	8.9		16"
4,500				12.3	11.4	10.7	10.0	16"

<sup>1</sup> Design parameters are identified in Figure 6.

**Table 7. Minimum Thermal Resistance of Horizontal Insulation at Corners ( $R_{hc}$ )<sup>1</sup>**

AFI (°F <sub>100</sub> )	$L_c$ (inches)	R-Values at Various Widths of Horizontal Insulation						Footing Depth
		Width of Horizontal Insulation at Corners, $D_{hc}$ (in inches)						
		16"	24"	30"	36"	42"	48"	
≤ 2,250	0.0	0.0						16"
2,625	40	6.5	4.9	4.0				16"
3,000	40	9.6	8.6	8.0	7.4			16"
3,375	60		11.1	10.5	9.8	9.1		16"
3,750	60		13.1	12.5	12.0	11.2	10.8	16"
4,125	60			14.5	13.7	13.0	12.5	16"
4,500	80				15.9	15.1	14.8	16"

<sup>1</sup> Design parameters are identified in Figure 6.

## Detailed FPSF Design Method – Unheated Buildings

In following the detailed design procedure for unheated buildings, the designer has the flexibility to increase foundation depths to reduce horizontal ground insulation requirements. In addition to the AFI at the selected return period, the Mean Annual Temperature (MAT) must be taken into account.

Figure 7 illustrates the parameters for design of FPSFs in unheated buildings. The following steps outline the detailed design approach for unheated buildings.

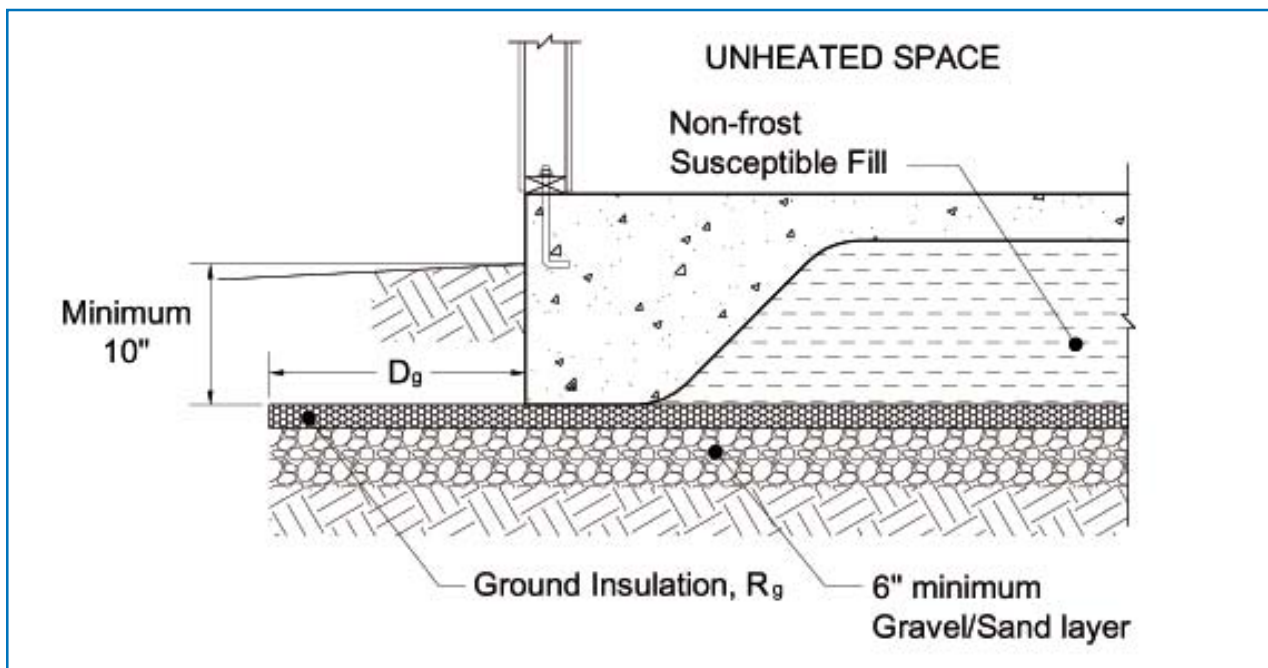

*Figure 7. FPSF Detailed Design Parameters – Unheated Buildings*

## Design Steps – Detailed FPSF Design Method for Unheated Buildings

### Step 1: Determine Air Freezing Index, AFI, and Mean Annual Temperature, MAT

Select the 100-year return period design air freezing index,  $^{\circ}\text{F}_{100}$ , from Figure 4. The AFI values are conservative because they are not adjusted for the insulating benefit of a normal snow cover on the ground. A lower return period value may be used for less important structures or those that are resilient to infrequent ground freezing, such as detached garages. Alternate AFI return periods are calculated by the National Oceanic and Atmosphere Administration (NOAA) and can be referenced at <http://www4.ncdc.noaa.gov/ol/9712/AFI-pubreturn.pdf>. MAT is also available on the NOAA website at <http://www.ncdc.noaa.gov/oa/climate/research/cag3/cag3.html>

AFI = \_\_\_\_\_

MAT = \_\_\_\_\_

### Step 2: Select Placement of Ground Insulation, $D_g$

A continuous ground insulation layer with a 6-inch gravel or other non-frost susceptible base must be placed below the entire foundation of unheated buildings. The ground insulation must extend outside the foundation a minimum width,  $D_g$ , determined from Table 8, as detailed in Figure 7. In unheated building foundations,  $D_g$  is the same at both corner and wall locations. Outside the foundation perimeter, the insulation must have a minimum of 10 inches of soil cover.  $D_g$  may be reduced by 1 inch for every inch the insulation is buried beyond the 10-inch minimum cover.

$D_g$  = \_\_\_\_\_

### Step 3: Select the Minimum Effective R-value of Ground Insulation, $R_g$

Select the minimum R-value,  $R_g$ , required for the ground-insulating layer from Table 8, based on the AFI and MAT from Step 1.  $R_g$  may be reduced by R-0.3 for every 1" the underlying non-frost susceptible layer is increased beyond the 6" minimum thickness.  $R_g$  may also be reduced by R-0.25 for every 1-inch increase in soil cover over the ground insulation, above the 10" minimum.

$R_g$  = \_\_\_\_\_

**Step 4: Select Thickness and Performance of Ground Insulation**

Based on the required  $R_g$  value determined in Step 3, select an adequate thickness of ground insulation using the effective R-value from Table 2, column 5h. In severe climates, insulation may need to be layered to meet the required thickness.

The horizontal polystyrene foam used beneath unheated buildings must be calculated to support the superimposed loads of the building. Columns 3 and 6 of Table 2 contain the density and bearing capacity, respectively, of the several different types of insulation.

$R_g = \frac{\text{ } \text{ divided by } \text{ } \text{ (effective R-value) = } \text{ } \text{ PS, Type } \text{ } \text{ of } \text{ } \text{ " thickness.}$

Density \_\_\_\_\_

Bearing Capacity \_\_\_\_\_

**Table 8. Minimum Values for Design of FPSFs in Unheated Buildings**

Mean Annual Temperature, MAT (°F) <sup>1</sup>		32	36	38	40	≥ 41
AFI (°F <sub>100</sub> )	D <sub>g</sub> (inches)	Minimum Thermal Resistance of Horizontal Insulation, R <sub>g</sub>				
≤ 750	30	5.7	5.7	5.7	5.7	5.7
1,500	49	13.1	9.7	8.5	8.0	6.8
2,250	63	19.4	15.9	13.6	11.4	10.2
3,000	79	25.0	21.0	18.2	15.3	14.2
3,750	91	31.2	26.1	22.7	-	-
4,500	108	37.5	31.8	-	-	-

<sup>1</sup> See NOAA website for MAT. <http://www.ncdc.noaa.gov/oa/climate/research/cag3/cag3.html>

## General

The construction of an FPSF is similar to that of a conventional foundation. Often the only difference is a shallower footing/foundation excavation and the attendant labor and material cost savings. Many of the steps, such as rough grading, foundation layout, preparation of subgrade, wall forming, steel reinforcing, and casting of the concrete, are all similar to conventional practices.

FPSFs can be constructed using one of many approaches, including a monolithic slab, an independent slab and stem wall, or a permanent wood foundation. Although the details shown here illustrate techniques for the construction of new homes, the FPSF technique can also be applied to additions to homes with existing conventional foundations, and even walk out basements.

The FPSF construction details shown here reflect satisfactory practices for several typical situations. The drawings shown are generic in that they must be modified to meet the requirements specific to the site, such as insulation dimensions. Of key importance is the proper placement, sizing, and selection of the type of insulation.

**Brick veneer.** A brick ledge can provide a cold bridge if it isn't detailed properly. Insulation of equal thermal resistance value to the vertical insulation required in the design should be placed horizontally along the brick ledge. Figure 8 details the insulation continuity that must be preserved at the exterior of the FPSF. Note that only insulations with high bearing capacity should be

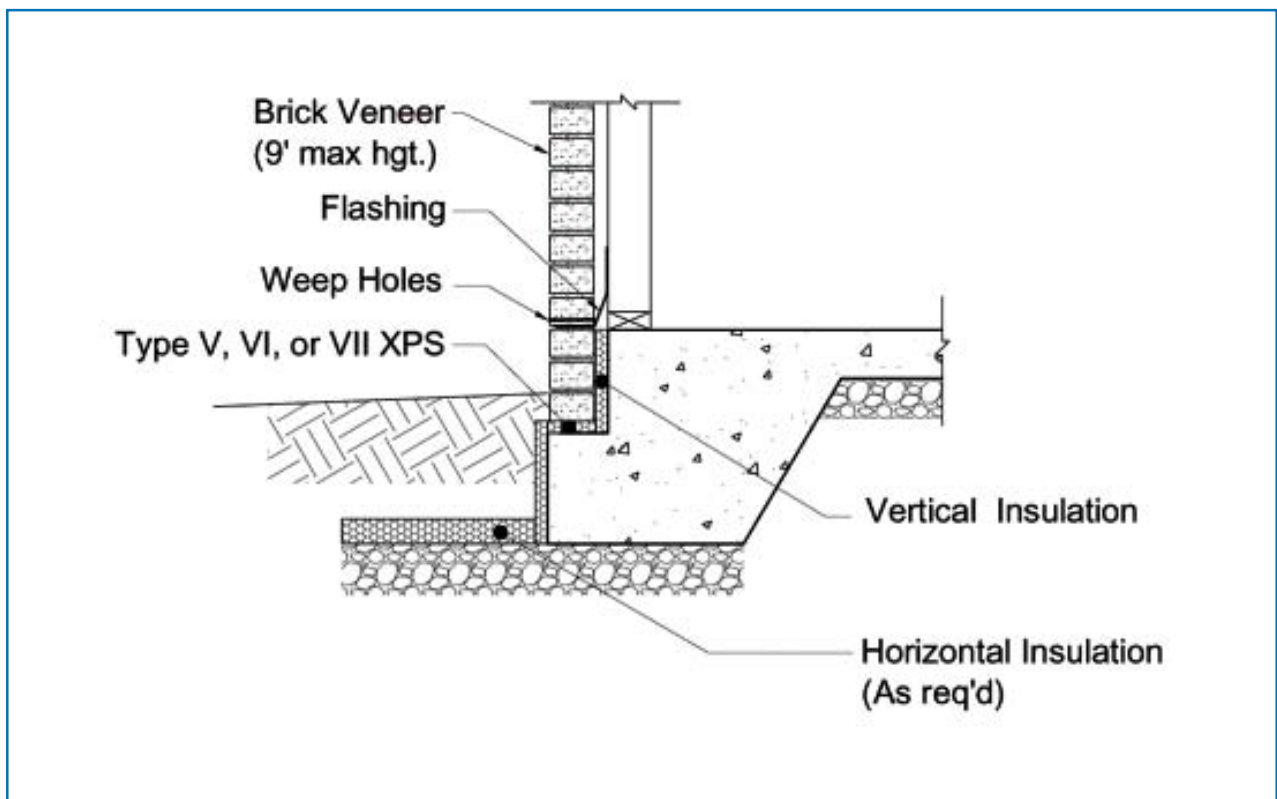

Figure 8. Brick Veneer Application



selected for installation along the ledge, so that deformation of the foam when the weight of the brick is applied will not compromise the appearance of the facade.

As with all brick veneers, it is important that these are flashed and installed properly above ground and weepholes, so that any water flowing down the drainage plane behind the veneer is channeled to the outside.

**Cold bridges, prevention.** Cold bridges are created when building materials with high thermal conductivity, such as concrete, are directly exposed to outside temperatures. Figure 9 details where some of these conditions can occur. Foundation insulation should be placed so that continuity is maintained with the insulation of the house envelope. Cold bridges may increase the potential for frost heave, or at the least, create localized lower temperatures or condensation on the slab surface. Care must be taken during construction to ensure proper installation of the insulation.

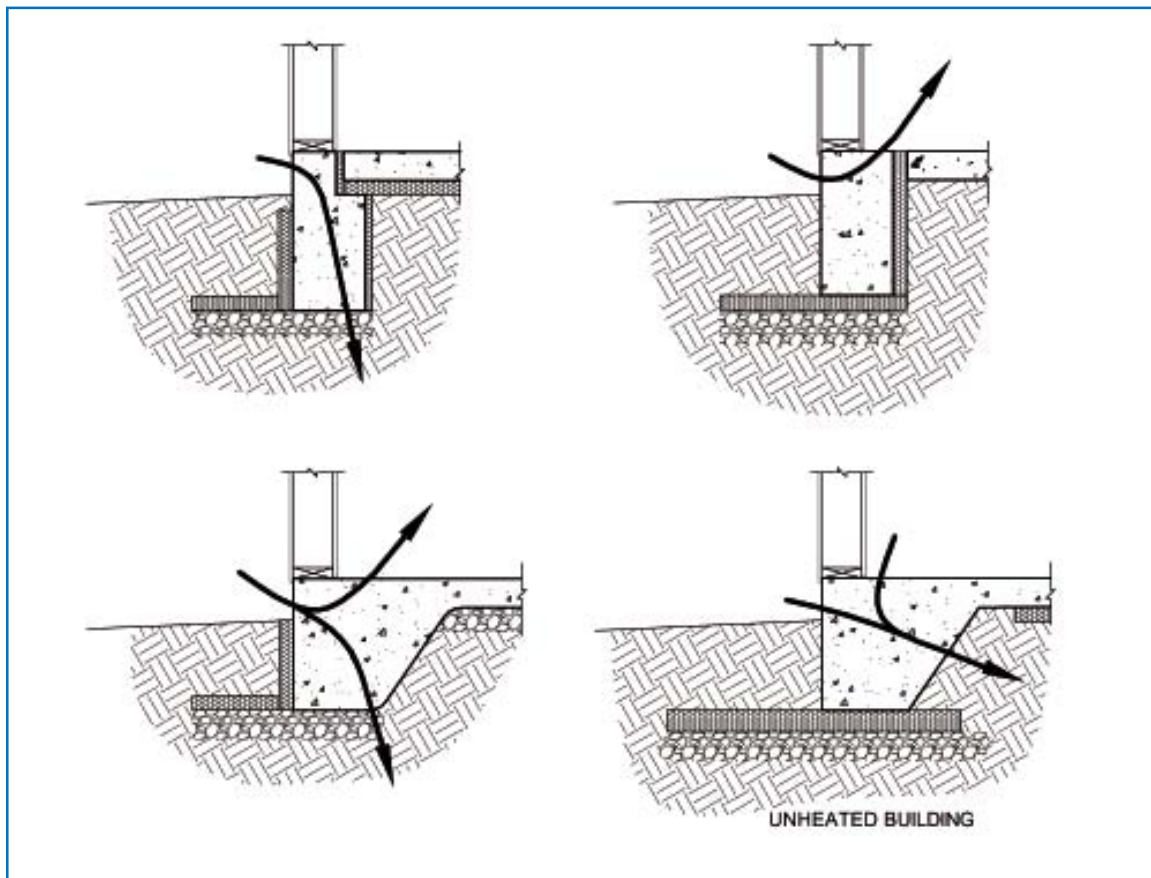

**Figure 9. Typical Illustrations of Cold Bridges**

**Drainage.** Good drainage is important with any foundation, and an FPSF is no exception. Insulation performs better in dry conditions. Ensure that ground insulation is adequately protected from excessive moisture through sound drainage practices, such as sloping the grade away from the building and properly detailing the drainage plane of the above ground structure.

Insulation should always be placed above the level of the ground water table. A layer of gravel, sand, or similar material is recommended for improved drainage, as well as to provide a smooth surface for placement of any horizontal insulation. A minimum 6-inch drain layer, with outfall to daylight, approved storm drain, or dry well is required for unheated FPSF designs with horizontal insulation.

**Energy efficiency.** The minimum insulation levels shown in Table 2, will protect the soil around the foundation from frost. They also provide satisfactory slab surface temperatures to prevent moisture condensation, and satisfy a minimum degree of thermal comfort. Table 10, in Appendix IV, provides information on increasing thermal resistance values for insulation based on heating degree days in various regions.

FPSF effectiveness is predicated on successfully limiting cold bridging — use of a stem wall and slab (described later), in effect, can add a second thermal break between the slab and stem wall. Increasing the vertical wall insulation thickness above the minimum requirements for frost protection will also improve energy efficiency and thermal comfort.

**Excavation.** Generally, lightweight equipment is adequate for FPSF installations because minor excavation is required. Trenching machines are typically selected to perform the excavation of FPSFs that do not require horizontal insulation. As with any foundation, organic soil layers (top soil) should be removed to allow the foundation to bear on firm soil or compacted fills.

**Foundation height.** Polystyrene insulation boards are typically available in 24-inch and 48-inch widths by 8 foot length. For many FPSF designs, 24 inches is a practical width, as it insulates 16 inches of foundation below grade and 8 inches above grade.

**Freeze protection during construction.** The foundation should be completed and the building enclosed and heated prior to the freezing weather, similar to conventional construction practice.

**Heated slabs.** This design procedure can be applied to all slab-on-grade techniques, including those with in-slab heat. The design of FPSFs with insulated slabs with an R-value greater than 28, should follow the design procedures for unheated buildings. (See Table 5.)

**Landscaping and horizontal insulation.** In situations where wide horizontal insulation is required, the landscape plan should be carefully designed to avoid digging above the horizontal insulation.

**Insulation protection.** Because the vertical wall insulation around a foundation extends above grade and is subject to ultraviolet radiation and physical abuse, that portion and 6" below grade, must be protected with a coating or covering that is both tough and durable. Care should be taken to prevent insulation damage during handling, storage, construction, and backfilling. Appendix I provides information on protective coatings.

## Monolithic Slab

Construction of an FPSF monolithic slab is very similar to that of a conventional slab. (See Figure 10.) A common technique is to install the vertical insulation boards inside the formwork and trench before placing the concrete. This allows the trench to act as the form for the lower part of the FPSF, while assuring full depth coverage of the footing/foundation with foam. The above ground step or return is of a dimension that can be formed with 2x lumber or slab forms.

If both vertical and horizontal insulation are used, the vertical wall insulation should be placed first. Horizontal insulation, where used, should be placed directly on a 4" layer of drainable material that is not frost susceptible. Measures should be taken to ensure a smooth, compacted, and well-drained bed beneath the horizontal insulation.

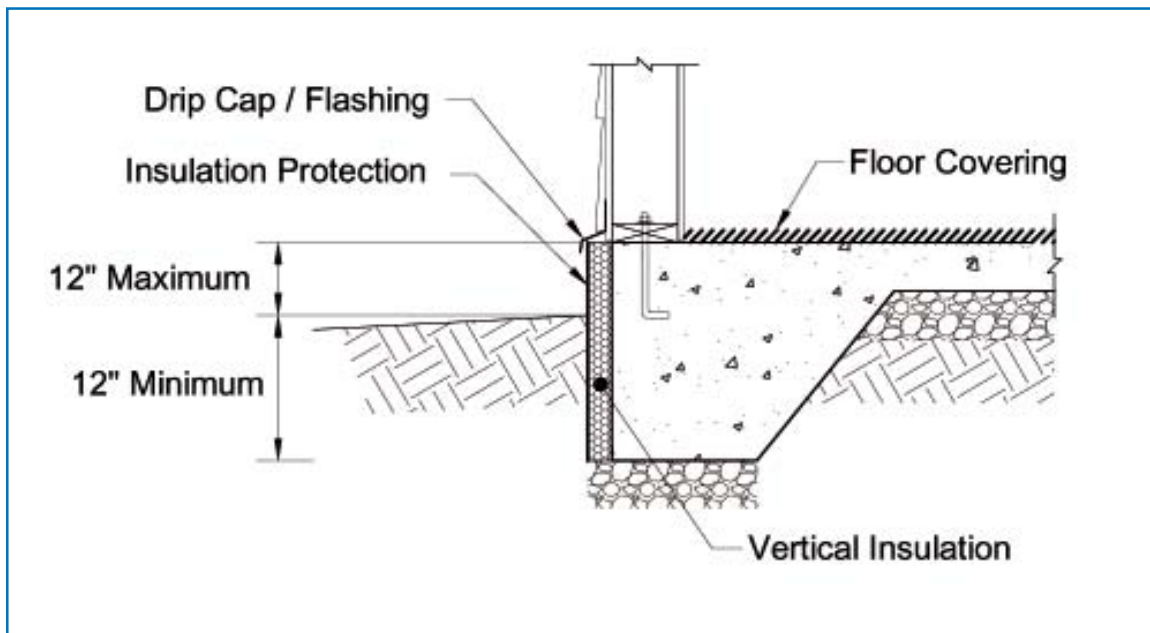

Figure 10. Typical FPSF Monolithic Slab

## Independent Slab and Stem Wall

As noted previously, FPSF can also be adapted to foundations constructed with an independent stem wall and ground supported slab. (See Figures 11 and 12.) The stem wall and slab technique has the same insulation and drainage requirements as a monolithic slab. If a separate footing is used, as may be required by local soil conditions or choice of stem wall material, such as concrete masonry units, the footing must be located below the horizontal insulation. In any case, any horizontal insulation should be a minimum 12 inches below grade. The wall may be constructed of poured concrete, concrete masonry units, wood, or other acceptable materials. Some examples are shown below.

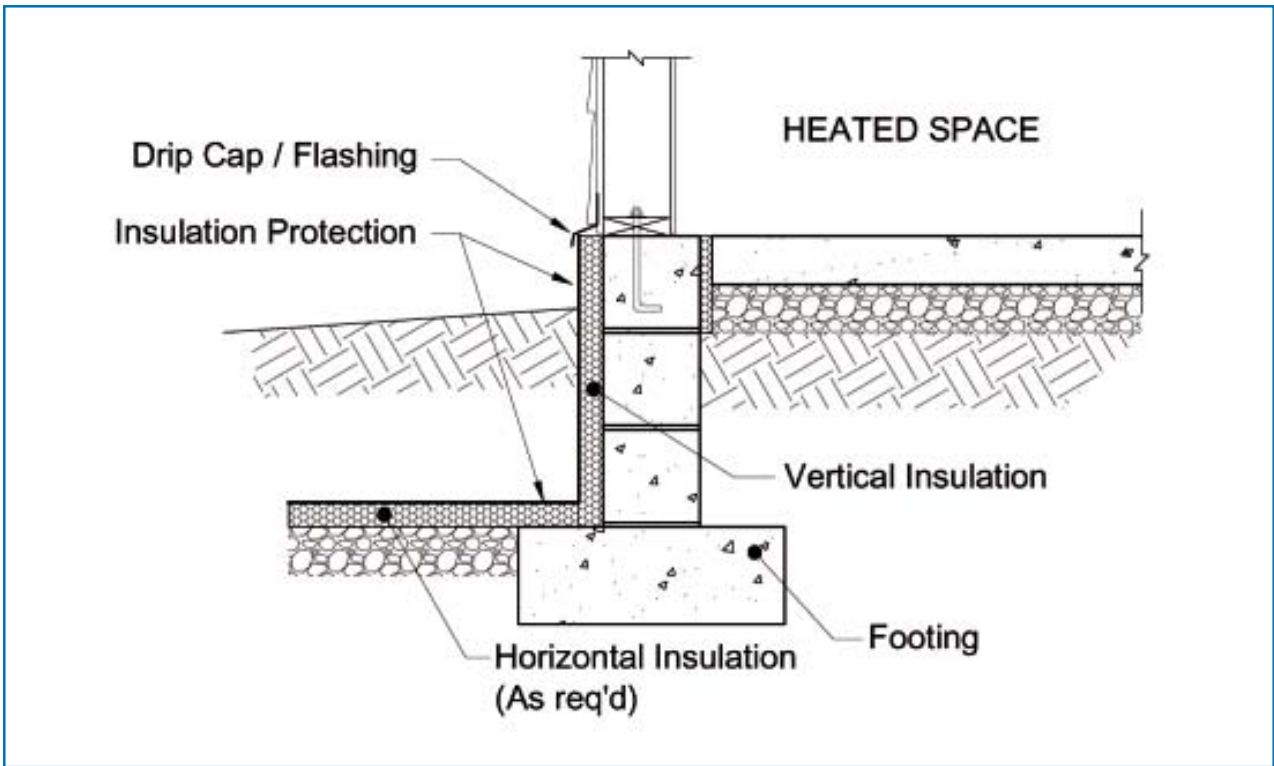

Figure 11. Independent Block Stem Wall

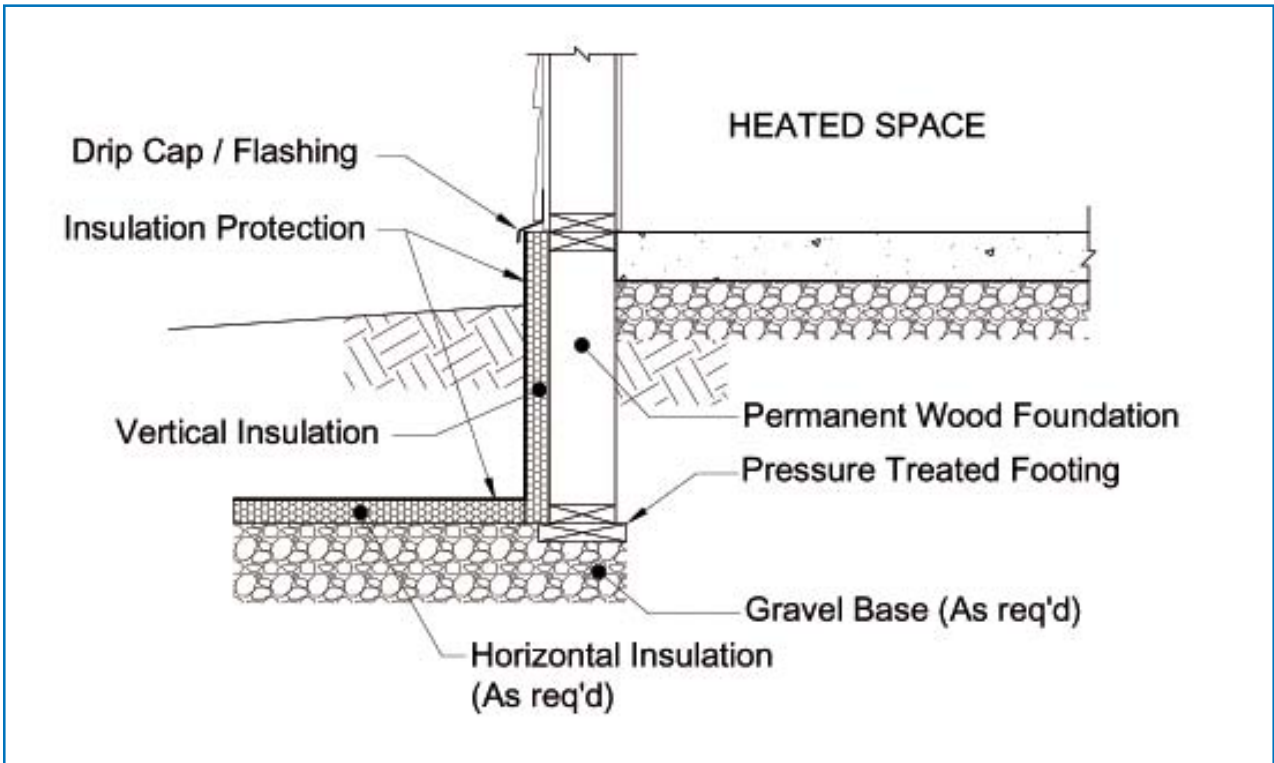

Figure 12. Typical Permanent Wood FPSF

## Unventilated Crawlspace

The construction of an FPSF crawlspace is similar to that of a conventional crawlspace, except that the crawlspace is constructed without vents to the outside. The crawlspace includes a continuous poly moisture barrier at the interior ground level and detailed measures are taken to ensure that the crawlspace is sealed against moisture intrusion and air infiltration. Figure 13 illustrates these details.

Because this design guide is focused on FPSFs in heated residential structures, the crawlspace should also be conditioned. Mechanical ventilation can be supplied via forced air HVAC ductwork located in the floor assembly above the crawlspace. Providing for air change in the crawlspace using the HVAC system also heats the crawlspace.

Unventilated crawlspace designs shall follow the Detailed Design Method and limit the height above grade to 24" ( $h \leq 24"$ , Table 5). Additionally, the nominal R-value of the floor assembly ( $R_f$ ) should be limited to less than R-28. See Table 5.

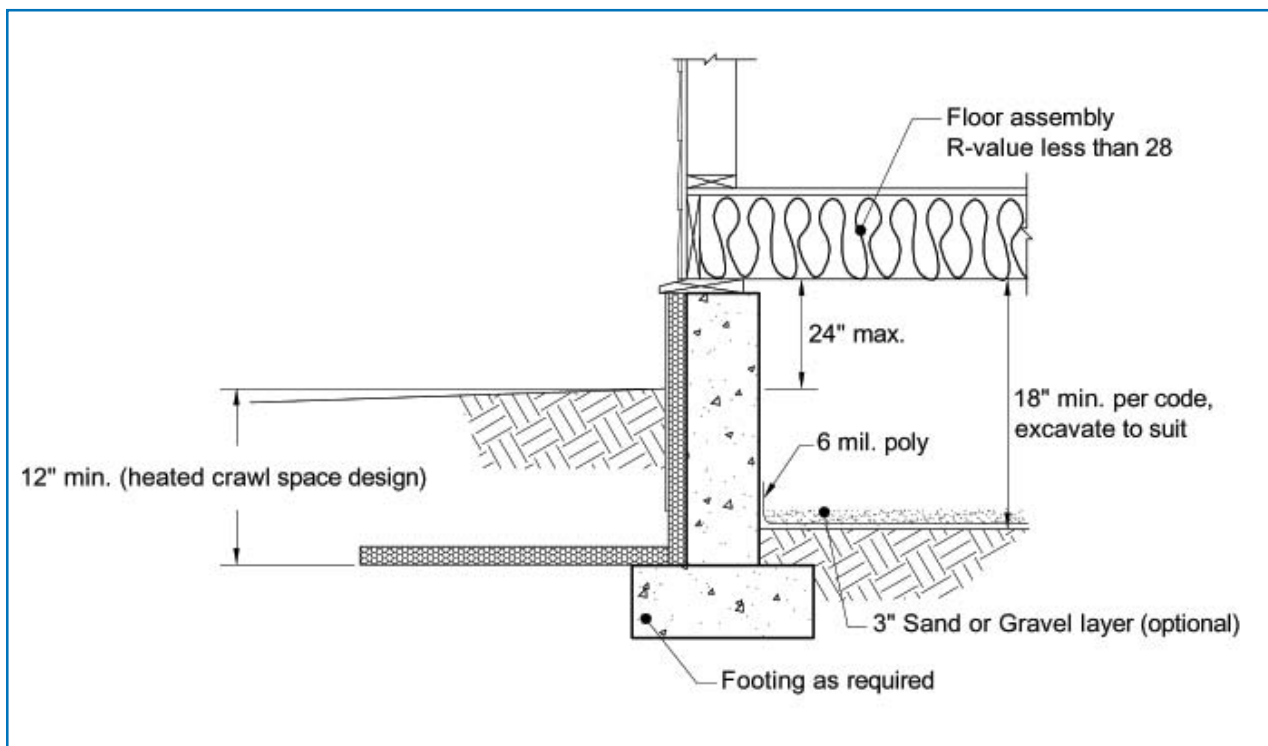

*Figure 13. Typical Unventilated Crawlspace*

## Unheated Areas in Otherwise Heated Buildings

Many heated buildings may have small areas that are unheated, such as entries and porches, and therefore require special consideration, as detailed in Figure 14. The design for these cases follows the Detailed FPSF Design Method for Unheated Buildings.

In the case of a home with an attached garage, the garage footings at the garage slab perimeter can either be designed as an FPSF using the unheated building method, or they may be designed conventionally, and filled with compacted stone or gravel to facilitate forming both the FPSF and the conventional footing at the same time. Figure 15 details a section where the garage slab meets the main house FPSF.

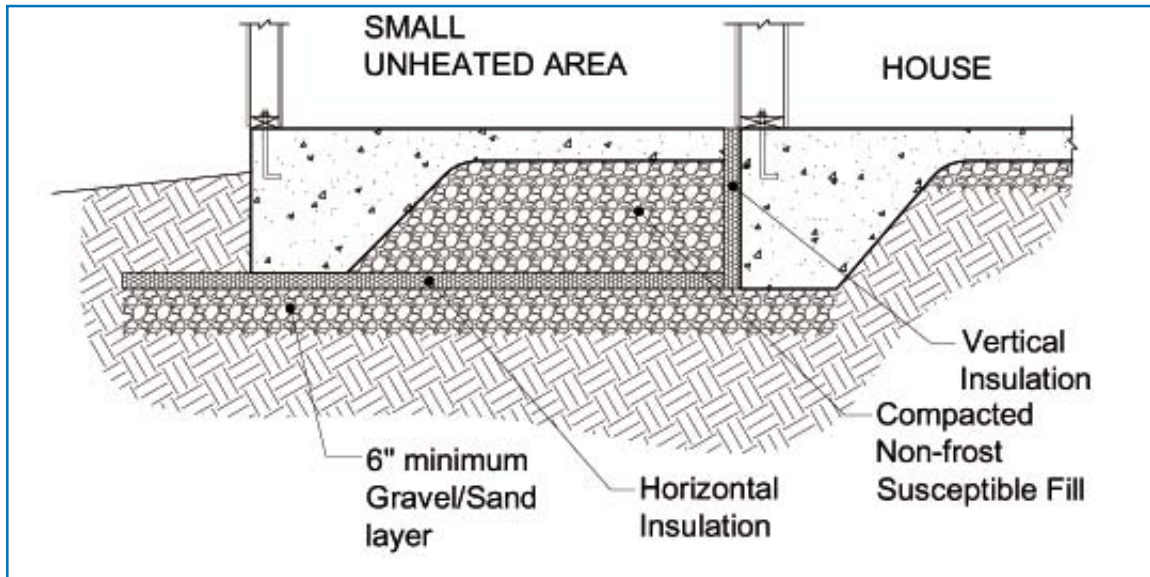

Figure 14. Typical Detail for Unheated Area

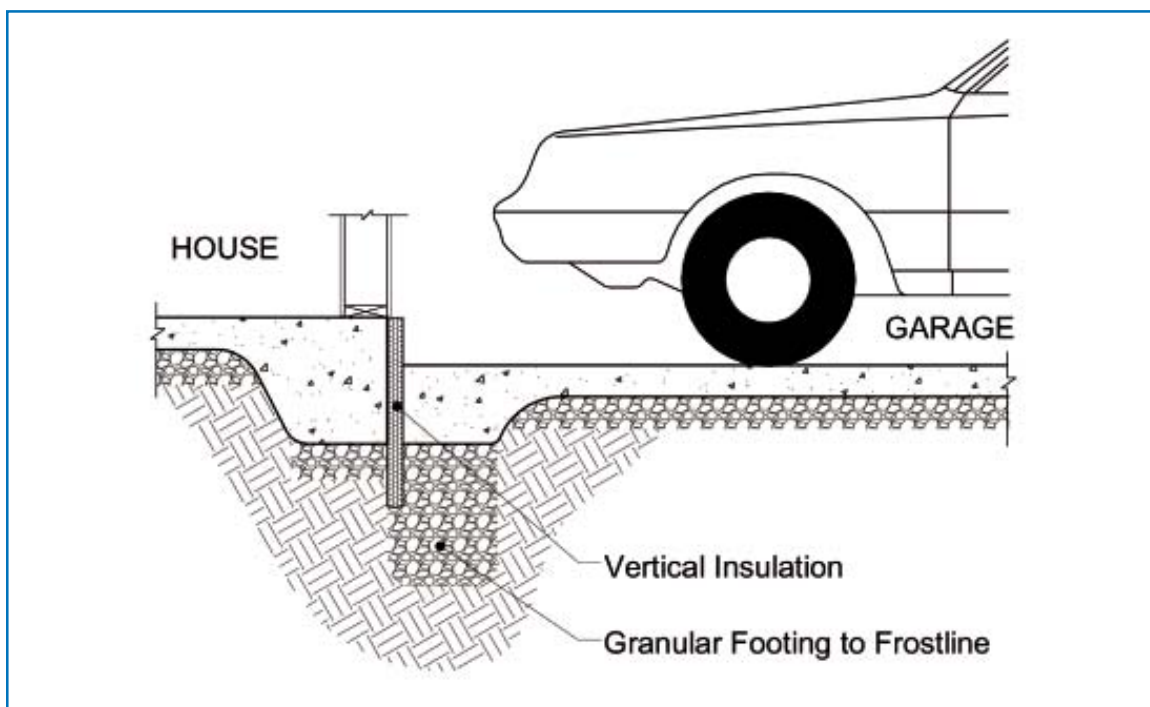

Figure 15. Typical Detail at Garage (FPSF Adjacent to Conventional)

## Sources for Polystyrene Foam Insulation Protective Coatings

Some methods to consider for the protection and finishing of foam insulation are a stucco finish system or similar brush-on coating, pre-coated insulation products, flashings, pressure treated plywood, and cementitious board. The protective finish should be applied before backfilling, because it must extend at least six inches below grade, or, in a horizontal application, cover any foam extending more than 24" from the foundation. Asphalt or cement surfacing at grade is another acceptable method of protecting horizontally installed foam. The builder should always verify that protective material is compatible with the insulation because polystyrene degrades in contact with hydrocarbon solvents such as gasoline, benzene, diesel fuel, and tar.

**Multicoat® Products** manufactures pool products that can be used to finish many surfaces, including polystyrene foam sheets. Their Slatex system consists of a below ground spray-on elastomeric product, **Mulasticoat®**, topped with a latex-modified cementitious dry mix, Scratch Kote. The finish coat can be spray or roller applied. <http://www.multicoat.com/skp.html>

**Protecto® Wrap's, Protecto® Bond Insulation Wrap**, is a peel and stick exterior above grade foam insulation protective membrane. The manufacturer states that the polymer-coated waterproofing membrane has the ability to withstand impacts, UV degradation, mold and mildew. The integrated finish has the appearance of smooth, light grey, stucco. This surface can be used as is and will accept paint. Protecto® Wrap has several asphaltic peel and stick products that may be used for below ground protection, such as, PW100-60 XL Waterproofing Membrane. <http://www.protectowrap.com>

**Styro Industries, Inc.** offers cementitious foam coatings. Products are available in several colors for installation by various application methods—spray, trowel, or brush. <http://www.styro.net>

## Common Questions and Answers About FPSFs

Answers to some common questions are provided here to benefit those interested in this technology.

### **Question No. 1: How does insulation stop frost heave from occurring?**

Frost heave can only occur when all of the following three conditions are present: 1) the soil is frost susceptible (large silt fraction), 2) sufficient moisture is available (soil is above approximately 80 percent saturation), and 3) sub-freezing temperatures are penetrating the soil. Removing one of these factors will negate the possibility of frost damage. Insulation as required in this design guide will prevent underlying soil from freezing (an inch of polystyrene insulation, R4.5, has an equivalent R-Value of about 4 feet of soil on average). The use of insulation is particularly effective on a building foundation for several reasons. First, heat loss is minimized while storing and directing heat into the foundation soil — not out through the vertical face of the foundation wall. Second, horizontal insulation projecting outward will shed moisture away from the foundation further minimizing the risk of frost damage. Finally, because of the insulation, the frost line will not penetrate as deeply into the soil around the foundation.

### **Question No. 2: Does the soil type or ground cover (e.g., snow) affect the amount of insulation required?**

By design, the proposed insulation requirements are based on the worst-case ground condition of no snow or organic cover on the soil. Likewise, the recommended insulation will effectively prevent freezing of all frost-susceptible soils. Because of the heat absorbed (latent heat) during the freezing of water (phase change), increased amounts of soil water will tend to moderate the frost penetration or temperature change of the soil-water mass. Since soil water increases the heat capacity of the soil, it further increases the resistance to freezing by increasing the soil's "thermal mass" and adding a significant latent heat effect. Therefore, the proposed insulation requirements are based on a worst-case, silty soil condition with sufficient moisture to allow frost heave but not so much as to cause the soil itself to drastically resist the penetration of the frost line. Actually, a coarse grained soil (non-frost susceptible) which is low in moisture will freeze faster and deeper, but with no potential for frost damage. Thus, the proposed insulation recommendations effectively mitigate frost heave for all soil types under varying moisture and surface conditions.

### **Question No. 3: How long will the insulation protect the foundation?**

This question is very important when protecting homes or other structures which have a long life expectancy. The ability of insulation to perform in below-ground conditions is dependent on the product type, grade, and moisture resistance. In Europe, polystyrene insulation has been used to protect foundations for nearly 40 years with no experience of frost heave. Thus,



with proper adjustment of R-values for below-ground service conditions, both extruded polystyrene (XPS) and expanded polystyrene (EPS) can be used with assurance of performance. In the United States, XPS has been studied for Alaskan highway and pipeline projects, and it has been found that after 20 years of service and at least 5 yrs of submergence in water that the XPS maintained its R-value (refer to McFadden and Bennett, *Construction in Cold Regions: A Guide for Planners, Engineers, Contractors, and Managers*, J. Wiley & Sons, Inc., 1991. pp328-329).

**Question No. 4: What happens if the heating system fails for a time during the winter?**

For all types of construction, heat loss through the floor of a building contributes to geothermal heat storage under the building that is released to the foundation perimeter. Using insulated footings will effectively regulate the stored heat loss and retard penetration of the frost line during a period of heating system failure or set-back. Conventional foundations, with typically less insulation, do not offer this level of protection and the frost may penetrate more quickly through the foundation wall and into interior areas below the floor slab. With ad-freezing (the frozen bond between the water in the soil and the foundation wall), frost does not need to penetrate below footings to be dangerous to light construction. In this sense, frost protected footings are more effective in preventing frost damage.

The proposed insulation requirements are based on highly accurate climate information verified by up to 86 years of winter freezing records for over 3,000 weather stations across the United States. The insulation is sized to prevent foundation soil freezing for a 100-year return period winter freezing event with a particularly rigorous condition of no snow or ground cover. Even then, it is highly unlikely that during such an event there will be no snow cover, sufficiently high ground moisture, and an extended loss of building heat.

**Question No. 5: Why are greater amounts of insulation needed at the corners of the foundation?**

Heat loss occurs outward from the foundation walls and is, therefore, intensified at the proximity of an outside corner because of the combined heat loss from two adjacent wall surfaces. Consequently, to protect foundation corners from frost damage, greater amounts of insulation are required in the corner regions. Thus, an insulated foundation design will provide additional protection at corners where the risk of frost damage is higher.

**Question No. 6: What experience has the U.S. seen with this technology?**

Frost protected insulated footings were used as early as the 1930s by Frank Lloyd Wright in the Chicago area. But since that time, the Europeans have taken the lead in applying this concept over the last 50 years. There are now over 1 million homes in Norway, Sweden, and Finland with insulated shallow footings that are recognized in the building codes as a standard practice. In the United States, insulation has been used to prevent frost heave in

many special engineering projects (i.e., highways, dams, pipelines, and engineered buildings). Its use on home foundations has been accepted by model codes, and there are several thousand homes with frost protected insulated footings that have been constructed in the United States (including Alaska).

To verify the technology in the United States, five test homes were constructed in Vermont, Iowa, North Dakota, and Alaska. The homes were instrumented with automated data acquisition systems to monitor ground, foundation, slab, indoor, and outdoor temperatures at various locations around the foundations. The performance observed was in agreement with the European experience in that the insulated footings prevented the foundation soil from freezing and heaving even under rigorous climatic and soil conditions (refer to U.S. Department of Housing and Urban Development, *"Frost Protected Shallow Foundations for Residential Construction"*, Washington, DC, 1993).

**Question No. 7: How energy efficient and comfortable are slab foundations with frost protected footings?**

The insulation requirements for frost protected footings are minimum requirements to prevent frost damage. The requirements will provide a satisfactory level of energy efficiency, comfort, and protection against moisture condensation. Since these requirements are minimums, additional insulation may be required to meet more stringent energy codes. See Appendix IV for more on this subject.

## Building Material R-Values

Table 9. Nominal Thermal Resistance of Common Materials

Description	Density (lb/ft <sup>3</sup> )	Nominal R-value (per inch)
<b>BUILDING MATERIALS</b>		
Plywood/OSB/Subfloor	34	1.25
Particleboard, Low-Density	37	1.41
Particleboard, High-Density	62.5	0.85
Particleboard, Underlayment	40	1.31
Softwoods	35	0.9
Hardwoods	40	0.8
Brick	100	0.25
8" Concrete Masonry Unit (CMU) with Perlite Fill	—	2.1
Cement Mortar	120	0.15
Concrete	140	0.05
6 mil Plastic	—	Negligible
EPS Insulation, Type II	1.3	4.0
EPS Insulation, Type IX	1.8	4.2
XPS Insulation, Types IV, V, VI, VII	1.6 - 3.0	5.0
<b>FINISH FLOORING MATERIALS</b>		
Carpet and Fibrous Pad		2.08
Carpet and Rubber Pad		1.23

## Insulation Requirements for Energy Conservation

At the time that this guide was prepared, twenty-five states and many local municipalities had adopted the IRC and or the International Energy Conservation Code® (IECC). Chapter 11 of the IRC, *Energy Conservation*, prescribes thermal resistance values for slab and crawl space walls in conventional light framed structures of 2x4 studs with a maximum glazing ratio of 15%. Some values are greater than prescribed in Table 3 for FPSF performance, only. Stakeholders who want to incorporate the IRC's energy conservation prescriptive methods may use Table 10, of this section. The insulation R-values represented in Table 10 are significantly higher than the minimums required of the FPSF design, for most climates. Designs that follow the IECC, which allows tradeoffs in building component R-values, should use Table 3 and adjust the thermal resistance values of the foundation insulation upward.

**Table 10. Insulation Requirements for FPSFs vs. Insulation Requirements for Energy Conservation in Heated Buildings<sup>1</sup>**

Requirement for FPSF Design				Requirement for Energy Conservation Design <sup>2</sup>			
Air Freezing Index (°F <sub>100</sub> ) <sup>3</sup>	Vertical Insulation R-Value <sup>4,5</sup>	Horizontal Insulation R-Value <sup>4,5</sup>		Heating Degree Days (HDD) <sup>6</sup>	Nominal Vertical Insulation R-Value <sup>5</sup>		
		Along Walls	At Corners		Base-ment	Slab	Crawl-space
1,500	4.5	NR	NR	< 2,000	Requirement is less than or approx. equal to FPSF		
1,500	4.5	NR	NR	2,000-2,999	6	4	7
				3,000-3,999	8	5	10
				4,000-4,999	9	6	17
				5,000-5,999	10	9	19
				6,000-6,999	11	11	20
2,000	5.6	NR	NR	7,000-8,499	11	13	20
				6,000-6,999	11	11	20
2,500	6.7	1.7	4.9	7,000-8,499	11	13	20
				8,500-8,999	18	14	20
				9,000-12,999	19	18	20
3,000	7.8	6.5	8.6	7,000-8,499	11	13	20
				8,500-8,999	18	14	20
				9,000-12,999	19	18	20
3,500	9.0	8.0	11.2	7,000-8,499	11	13	20
				8,500-8,999	18	14	20
				9,000-12,999	19	18	20
4,000	10.1	10.5	13.1	7,000-8,499	11	13	20
				8,500-8,999	18	14	20
				9,000-12,999	19	18	20

<sup>1</sup> These tables compare minimum R-value requirements for FPSF design and energy conservation design. To meet both requirements, the designer must know the AFI and the HDD. The minimum R-value for an FPSF is determined with the AFI and the minimum R-value for energy conservation is determined with the HDD. The higher R-value of the two shall be used to meet both FPSF and energy design requirements.

<sup>2</sup> The R-values shown in this condensed table are for the HDD ranges indicated. Lower R-values may be obtained by using expanded tables, such as those in the International Energy Conservation Code (IECC) if desired.

<sup>3</sup> See Figure 4 for Air-Freezing Index (AFI) values.

<sup>4</sup> Use "Effective" R-values (Table 2) when choosing insulation for this application.

<sup>5</sup> Upgrading the vertical insulation in an FPSF to that required for energy conservation does not preclude the horizontal insulation requirement.

<sup>6</sup> Heating Degree Days are the aggregate of the difference between the simple daily average temperature and 65°, when the daily average falls below 65°. HDD information by region is available in the IRC, Table 602.1, local newspapers, and the Nat'l Oceanic and Atmospheric Administration, <http://www.ncdc.noaa.gov/oa/documentlibrary/hcs/hcs.html>

## REFERENCES

- American Society of Civil Engineers, *SEI/ASCE 32-01, Design and Construction of Frost-Protected Shallow Foundations*, 2001. <http://www.PUBS.ASCE.org>
- American Society of Testing and Materials (ASTM), ASTM C 578, *Standard Specification for Rigid, Cellular Polystyrene Thermal Insulation*. [www.astm.org](http://www.astm.org)
- International Code Council, [www.iccsafe.org](http://www.iccsafe.org)
- McFadden and Bennett, *Construction in Cold Regions: A Guide for Planners, Engineers, Contractors, and Managers*, J. Wiley & Sons, Inc., (1991).
- Morris, Richard A., *Frost-Protected Shallow Foundations: Current State-of-the-Art and Potential Application in the U.S.* Prepared for Society of the Plastics Industry, Inc.  
<http://www.nahb.org/generic.aspx?genericContentID=3326>
- NAHB Research Center for U.S. Department of Housing and Urban Development, *Design Guide for Frost-Protected Shallow Foundations*, Second Edition. [www.nahbrc.org](http://www.nahbrc.org)
- NAHB Research Center for U.S. Department of Housing and Urban Development, *Frost Protected Shallow Foundations in Residential Construction*, (1994).  
<http://www.huduser.org/publications/destech/frostprt.html>
- National Oceanic and Atmospheric Association (NOAA), *Climatic Data for Frost Protected Shallow Foundations Publications and Data*. <http://lwf.ncdc.noaa.gov/oa/fpsf>
- NOAA, *Mean Annual Temperature*,  
<http://www.ncdc.noaa.gov/oa/climate/research/cag3/cag3.html>



